

INSTALLATION, OPERATING AND MAINTENANCE



HIGH EFFICIENCY PACKAGED AIR TREATMENT UNIT

eNeRGy

0 - 180 kW

0 - 32 000 m³/h

ENERGY-IOM-1711-E



www.lennoxemea.com



LENNOX

eNeRGy

Installation, operating and maintenance

Ref : eNeRGy-IOM-1711-E

INSTALLATION MANUAL	4
SERVICE MANUAL	32

Original version is the English one. Other versions are translations.

All the technical and technological information contained in this manual, including any drawing and technical descriptions provided by us, remain the property of Lennox and must not be utilised (except in operation of this product), reproduced, issued to or made available to third parties without the prior written agreement of Lennox.

INSTALLATION MANUAL

Ref : eNeRGy-IOM-1711-E

INTRODUCTION	
Range description	6
Safety codes & regulations	7
TRANSPORT & HANDLING	
Dimensions and weights	11
Mandatory handling devices	13
Lifting the unit with a crane	14
INSTALLATION	
Minimum clearance around the unit installation	16
DELIVERY CHECKS	
Rating plate	17
Storage	17
Maintenance access	17
Condensate drains	19
Preliminary checks	19
Installation requirements	19
Connections	21
INSTALLATION ON A ROOFCURB	
Adjustable / Non-adjustable roofcurb	22
Levelling adjustable roofcurbs	23
Curbing and flashing	24
Positioning the rooftop on roofcurb	25
DUCT CONNECTIONS	
Recommandations for ducts connections	26
ELECTRICAL CONNECTIONS	
Main Switch Connection	28
Customer power cable inlet & BUS inlet	28
SENSOR MOUNTING	
CO2 or Advanced control pack Sensor	29
HEAT RECOVERY	
General description	30
Rotary wheel / Thermodynamic heat recovery	31

Left hand side horizontal supply airflow direction	HFSU
Right hand side horizontal supply airflow direction	HBSU
Horizontal return	HORE
Gravity exhaust damper	GEDD
Vertical power axial fan	PEFA
Vertical extraction EC plug fan	ERVL
Horizontal extraction EC plug fan	ERHL
High pressure extraction EC plug fan	HPER
Rotary wheel on vertical exhaust air	RWMV
Rotary wheel on horizontal exhaust air	RWMH
Thermodynamic heat recovery on vertical exhaust air	TRMV
Thermodynamic heat recovery on horizontal exhaust air	TRMH
eRecovery on refrigeration equipment's	ENRE
EU3 start-up kit (supplied mounted)	FEU3
G4 refillable metallic frame	REU4
G4 + F7	FEU7
G4 + F7 + F9	FEU9
Kit low ambient condition EC condenser fan	LONO
Compressor acoustic insulation	COJA
Refrigerant leak detection	RLKD
Variable Speed Compressor	VSCP
High Pressure EC plug fan	HPEC
Cooling & Heating Water coil - Standard	CHWS
Cooling & Heating Water coil - High	CHWH
Condensing gas burner - Standard - Vertical	GBSV
Condensing gas burner - High - Vertical	GBHV
Condensing gas burner - Standard - Horizontal	GBSH
Condensing gas burner - High - Horizontal	GBHH
300 mbar natural gas option	300M
37 mbar propane gas option	PROP
Electrical pre-heater - Standard	EPHS
Electrical pre-heater - Medium	EPHM
Electrical pre-heater - High	EPHH
Electrical heater - Standard	ELHS
Electrical heater - Medium	ELHM
Electrical heater - High	ELHH

LenGuard anti-corrosion condenser coil treatment	BLCO
LenGuard anti-corrosion condenser and evaporator coil treatment	BLCE
LenGuard anti-corrosion evaporator coil treatment	BLEV
LenGuard anti-corrosion water coil treatment (S)	BLWS
LenGuard anti-corrosion water coil treatment (H)	BLWH
LenGuard anti-corrosion thermodynamic recovery condenser and evaporator coil treatment	BLTR
LenGuard anti-corrosion eRecovery coil treatment	BLER
Container packing including wooden palette	PACK
DAD smoke detector	DADS
Fire thermostat	FIRS
CO2 sensor	CO2S
Energy Meter	ELME
Phase control	PHCT
Aluminium wires adaptor	ALWA
Comfort display	DC60
Service display	DS60
Multirooftop display	DM60
Dry Contact Board	DCBO
Advanced control pack (enthalpy and humidity control)	ADCP
LonWorks® interface RS485	ECLO
BACnet® interface RS485	BNET
ModBus interface RS485	MBUS
ModBus and BACnet® interface TCP/IP	MBIP
Lennox Oneweb	LXWB
Control supply pressure pressostat	PCPS
Electrical box fan motor >34°c outdoor temperature	EBFM
Electrical box fan motor >44°c outdoor temperature	EBFM2
Non Adjustable non insulated roofcurb 1	NAR1
Non Adjustable non insulated roofcurb 2	NAR2
Non Adjustable non insulated roofcurb 3	NAR3
Non Adjustable non insulated roofcurb 4	NAR4
Adjustable non insulated roofcurb 1	ADR1
Adjustable non insulated roofcurb 2	ADR2
Adjustable non insulated roofcurb 3	ADR3
Adjustable non insulated roofcurb 4	ADR4

Range description

The present manual applies to the following units

E	Type of unit : eNeRGy
014	Range of airflow x 1000 m3/h
A	A : Air cooled
H	H : Heat pump units
055	Indicative capacity in kW
F	F : Scroll compressor
M	M : Refrigerant R410A
1	Version 1
M	M = 3 phases

Safety codes & regulations

THE UNIT MUST BE INSTALLED IN ACCORDANCE WITH LOCAL SAFETY CODES AND REGULATIONS AND CAN ONLY BE USED IN WELL VENTILLATED AREA.

PLEASE READ CAREFULLY THE MANUFACTURER'S INSTRUCTIONS BEFORE STARTING THIS UNIT.

INSPECTIONS AND REQUALIFICATION ACCORDING PRESSURE EQUIPMENT DIRECTIVE MUST FOLLOW THE LOCAL REGULATIONS WHERE THE UNIT IS INSTALLED.

EMC DIRECTIVE COMPLIANCE

WARNING:

This equipment is a "B class" according EMC Directive. The units meet the following hardest environments standards:
EN 61000-6-3: program for environment residential, commercial and light industry. EN 61000-6-2: immunity for industrial environments.

In emission devices having a rated current $I < 75A$:

- For machines with variable speed compressor, the short-circuit ratio R_{sce} is: 120 (EN 61000-3-12)
- For machines without variable speed compressor, the short-circuit ratio R_{sce} is: 66 (EN 61000-3-12)
- The maximum network impedance authorized Z_{max} is: 0.17 (EN 61000-3-11).

The differences between the various machines are only related to the power of the compressors and equipment that are associated. For conducted and radiated emission and immunity, these differences do not alter the results.

F-Gas REGULATION

Operators of refrigeration equipment's must comply with the obligations defined in:

- EU Regulation No 517/2014 on fluorinated greenhouse gases
- EC 1005/2009 on substances that deplete the ozone layer



Non-compliance with these requirements is an offence and liable of financial penalties.

Moreover, in case of problem it is mandatory to prove to the insurance company that the equipment complies with the F gas Regulation.

WARRANTY

The warranty of the unit is subject to the warranty definitions as agreed upon in the order. It is expected that the design and installation of the unit utilise good working practices. The warranty will be legally null and void if:

- **Service and maintenance have not been executed in accordance with the regulations; repairs have not been carried out by LENNOX personnel or have been implemented without prior written permission by LENNOX.**
- **Modifications have been made to the equipment without prior written permission by LENNOX.**
- **Settings and protections have been modified without prior written permission by LENNOX.**
- **Non-original or other than the prescribed refrigerants or lubricants are used.**
- **The equipment has not been installed and/or connected in accordance with the installation instructions.**
- **The equipment is being used improperly, incorrectly, negligently or not in accordance with its nature and/or purpose.**
- **A flow protection device is not fitted.**

In these circumstances LENNOX is indemnified from any product liability claims from third parties.

In the event of a warranty claim the machine serial number and LENNOX order number must be quoted.

WARNING - All the technical and technological information contained in this manual, including any drawing and technical descriptions provided by us, remain the property of LENNOX and must not be utilised (except in operation of this product), reproduced, issued to or made available to third parties without the prior written agreement of LENNOX. The technical information and specifications contained in this manual are for reference only. The manufacturer reserves the right to modify these without warning and without obligation to modify equipment already sold.

SAFETY

The safety information contained in this manual is provided as a guide for the safe handling of this installation. LENNOX does not vouch for the completeness of this information and can therefore not accept liability for any possible omissions. In the rooftops, heat is being transported by a pressurised refrigerant, with changes in pressure and temperature. For air cooled rooftops, fans have been provided to discharge heat into the environment. The protection of operating and maintenance personnel was central in the design of the rooftop. Safety features have been included to prevent excessive pressure in the system. Sheet metal parts have been fitted to prevent inadvertent contact with (hot) pipes. For air cooled rooftops, the fans are equipped with protective grids and the electrical control panel is completely touch-proof. This excludes some parts operating at a safe voltage (< 24 Volt). The service panels can only be opened using tools.

The electrical control panel is completely touch-proof. This excludes some parts operating at a safe voltage (< 50 Volt). The service panels can only be opened using tools.

Notwithstanding that the rooftops are equipped with extensive safety and protection features, the utmost care and attention is needed when carrying out operations on the machine. Furthermore, ear protection should be worn when working on or in the vicinity of the rooftops. Operations on the cooling circuit or electrical equipment should be carried out by authorised personnel.

It is essential to follow non exhaustive recommendations hereunder:

- Never work on a unit that is still energized.
- Any manipulation (opening or closing) of a shut-off valve must be carried out by a qualified and authorised engineer. These procedures must be carried out with the unit shut-down.
- Never work on any of the electrical components, until the general power supply to the unit has been cut. During any maintenance operations on the unit, lock the power supply circuit in the open position ahead of the machine. If the work is interrupted, check the lock before resuming the work.
- **WARNING:** Even if the unit has been switched off, the power circuit remains energized, unless the unit or circuit disconnect switch is open. Refer to the wiring diagram for further details.
- For some units, a separate 220V power supply may exist, check the electrical wiring for more information's
- In case of maintenance operations on fans (grills replacement ...) ensure that the power is shut off to avoid automatic restart.
- Before the opening of the refrigerant circuit, check the pressure with manometers or pressure sensors, and purge the circuit.
- Never leave a unit stopped with valves closed on the liquid line, refrigerant could be trapped and the pressure would rise.
- All installation parts must be maintained by the personnel in charge, in order to avoid material deterioration and injuries to people. Faults and leaks must be repaired immediately. The authorized technician must have the responsibility to repair the fault immediately. Each time repairs have been carried out to the unit, the operation of the safety devices must be re-checked.
- Follow guidance and recommendations given in safety and machine standards such as EN378, ISO5149, etc.
- Do not use oxygen to purge lines or to pressurize a machine for any purpose. Oxygen gas reacts violently with oil, grease, and other common substances.
- Never exceed the specified maximum operating pressures. Verify the allowable maximum high- and low-side test pressures by
- Checking the instructions in this manual and the pressures given on the unit name plate.
- Do not use air for leak testing. Use only refrigerant or dry nitrogen.
- Do not unweld or flame cut the refrigerant lines or any refrigerant circuit component until all refrigerant (liquid and vapour) has been removed from rooftop. Traces of vapour should be displaced with dry air nitrogen. Refrigerant in contact with an open flame produces toxic gases.
- Do not siphon refrigerant
- Avoid spilling liquid refrigerant on skin or splashing it into the eyes. Use safety goggles. Wash any spills from the skin with soap and water. If liquid refrigerant enters the eyes, immediately and abundantly flush the eyes with water and consult a doctor.

Safety definition

The rooftops meet the following safety definitions, and is provided with CE markings if applicable (for further information see EU declaration).

- | | |
|---|--|
| - EN-378-2016 | - Gas Equipment Directive 2009/142/EC |
| - 2006/42/EC "Machine Directive" | - 2014/35/EU Low Voltage Directive |
| - EN-60204-1 | - 2011/65/EU RoHS Directive |
| - 2014/30/EU "EMC Directive" | - 2012/19/EU WEEE |
| - Pressure Equipment Directive 2014/68/EU | - 2009/125/EC Ecodesign * (If applicable) |
| - EU 517/2014 F-Gas | - EC 1005/2009 |

Warning labels

The rooftop is marked with the following warning labels to alert to potential hazards (on or near the potentially hazardous part).

High temperatures	Electrical Voltage	Rotating parts	Sharp parts

Regularly check that the warning labels are still in the correct positions on the machine and replace them if necessary.

All units are compliant with the PED directive.



Warning:

1. **Attention:** The high-pressure safety switches are essential elements which guarantee the system remains within the admissible operating limits. Before switching on the installation, always ensure all electrical connections are correct on these elements which are used to isolate the electrical power supply to the compressor(s) they protect. Carry out a test to ensure the electrical power supply is effectively isolated when the pressure switch attains its set value.
2. In case of installation in a seismic zone or in a zone which may be effected by violent natural occurrences such as storms, tornados, floods, tidal waves, etc..., the installer and/or operator will refer to valid standards and regulations in order to ensure the devices required are available as our units are not designed to operate under such conditions without prior precautions.
3. The equipment is not designed to resist fire. The installation site will therefore have to respect valid standards with regard to protection against fire (emergency instructions, map...).
4. In case of exposure to corrosive external atmospheres or products, the installer and/or operator shall take the necessary precautions to avoid damage to the equipment and will make sure the equipment provided has the necessary and sufficient anti-corrosion protection.
5. To respect a sufficient number of supports for the piping according to their size and weight under operating conditions and to design the piping to avoid a water hammer phenomenon
6. For technical reasons, it is not possible to carry out hydrostatic tests on all our units so leak tests are carried out as a compensatory measure. (The entire circuit is checked using leak detectors). For machines charged with refrigerant, at the end of the test, an HP test is carried out in the factory to make sure the pressure switch is working properly.
7. Before any work is carried out on the refrigeration circuit, the dry air or nitrogen pressure our units are supplied with must be released (For units not charged with refrigerant in the factory.)
8. The emissions of refrigerant via the safety relief valves must be channeled to the exterior of the machine room. The outlet relief valve will have to be sized in compliance with EN13136.
9. Installation and maintenance of these machines must be carried out by personnel qualified to work on refrigeration equipment.
10. All interventions must be carried out in conformity with valid safety regulations (e. g.: NF EN 378), as well as the recommendations indicated on the labels and handbooks provided with the machine. All actions shall be taken to avoid access of unauthorized persons.
11. It is essential that any pipework or other components of the refrigeration circuit hazardous to people because of their surface temperature are insulated or identified.
12. Ensure that the installation zone (room or area) of the machine has restricted access and ensure the good condition of the covering.

The following note must be followed carefully**Main Safety Recommendations****All work on the unit must be carried out by a qualified and authorised employee.**

Non-compliance with the following instructions may result in injury or serious accidents.

Work on the unit:

- The unit shall be isolated from the electrical supply by disconnection and locking using the main isolating switch.
- Workers shall wear the appropriate personal protective equipment (helmet, gloves, glasses, etc.).

Work on the electrical system:

- Work on electric components shall be performed with the power off (see below) by employees having valid electrical qualification and authorisation.

Work on the refrigerating circuit(s):

- Monitoring of the pressures, draining and filling of the system under pressure shall be carried out using connections provided for this purpose and suitable equipment.
- To prevent the risk of explosion due to spraying of coolant and oil, the relevant circuit shall be drained and at zero pressure before any disassembly or unbrazing of the refrigerating parts takes place.
- There is a residual risk of pressure build-up by degassing the oil or by heating the exchangers after the circuit has been drained. Zero pressure shall be maintained by venting the drain connection to the atmosphere on the low pressure side.
- The brazing shall be carried out by a qualified brazier. The brazing shall comply with standard NF EN1044 AG107 (minimum 30% silver).

Replacing components:

- Replacement of components shall be carried out using spare parts, or using parts approved by LENNOX.
- Only the refrigerant shown on the manufacturer's nameplate shall be used, to the exclusion of all other products (refrigerant blends, hydrocarbons, etc.).

Transport – Handling- Access:

- Installation of the unit and accessibility must be compliant with the local regulations. Ensure that all access equipments allow maintenance operation in safety (electrical cabinet, main switch, panels, filter, refrigerant circuit...)
- It is strictly forbidden to walk or store equipment or material on top of the rooftop unit

Rooftop installation in heavy wind locations

- The roofcurbs (vertical & horizontal) and rooftops installations are designed to withstand winds up to 80 km/h. Above this limit, it's recommended to take appropriate actions to secure the installation.
- Ensure the fresh air inlet does not face prevailing wind direction.

Filters:

- Do the filters fire classification's choice according to local regulations.

Fan compartment:

- Stop the power before accessing the fan compartment.

Warning: the unit is working under pressure. Never open the panels when the unit is working. Even after shutting down the unit, wait for 2 minutes until the fans are completely stopped before opening any panel.

Gas:

- Any work on gas module must be carried out by qualified personnel
- A unit with gas module must be installed in accordance with local safety codes and regulations and can only be used for outdoor installation.

Warning:

- The units are not designed to resist to a fire. The installation site must comply with the standards relating to fire protection.
- In case of installation of the units in an area recognized as being potentially at risk for natural phenomena (tornado, earthquake, tidal wave, lightning...), please follow the standards and regulations, and provide the necessary devices to prevent from these risks.

CAUTION :

In the event of fire, refrigerating circuits can cause an explosion and spray coolant gas and oil.

Dimensions and weights

Dimensions (mm)		E019NN000NN1M	E022NN000NN1M	E027NN000NN1M	E014AH055FM1M	E014AH065FM1M	E014AH075FM1M	E016AH085FM1M	E016AH105FM1M	E019AH066FM1M	E019AH076FM1M	E019AH086FM1M	E019AH106FM1M	E019AH124FM1M	
LENGTH (mm)	Base unit (frame only without air hood)	3138	3138	3138	4601	4601	4601	4601	4601	4601	4601	4601	4601	4601	
	+ Air hood additional length (fresh or exhaust)	<i>Depends on configuration and options (between 450mm and 612mm). Refer to drawing.</i>													
	+ Vertical extraction EC plug fan	961	961	961	961	961	961	961	961	961	961	961	961	961	961
	+ Rotary wheel on vertical exhaust air	588	588	588	588	588	588	588	588	588	588	588	588	588	588
	+ Thermodynamic heat recovery on vertical exhaust air	588	588	588	588	588	588	588	588	588	588	588	588	588	588
	+ Horizontal extraction EC plug fan	2177	2177	2177	2177	2177	2177	2177	2177	2177	2177	2177	2177	2177	2177
	+ Rotary wheel on horizontal exhaust air	0	0	0	0	0	0	0	0	0	0	0	0	0	0
	+ Thermodynamic heat recovery on horizontal exhaust air	0	0	0	0	0	0	0	0	0	0	0	0	0	0
	+ Condensing gas burner Standard Vertical	0	0	0	0	0	0	0	0	0	0	0	0	0	0
	+ Condensing gas burner High Vertical	0	235	235	0	0	0	0	0	0	0	0	0	0	0
	+ Condensing gas burner Standard Horizontal	1712	1712	1712	1713	1713	1713	1713	1713	1713	1713	1713	1713	1713	1713
	+ Condensing gas burner High Horizontal	1712	1712	1712	1713	1713	1713	1713	1713	1713	1713	1713	1713	1713	1713
WIDTH (mm)	Base unit (frame only without air hood)	2270	2270	2270	2270	2270	2270	2270	2270	2270	2270	2270	2270	2270	
	+ Air hood additional width (fresh or exhaust)	<i>Depends on configuration and options (between 441mm and 595mm). Refer to drawing.</i>													
HEIGHT (mm)	Base unit	1869	2275	2275	1869	1869	2024	2024	2024	1869	2024	2024	2024	2024	
	+ Rotary wheel on vertical exhaust air	406	0	0	406	406	251	251	251	406	251	251	251	251	
	+ Rotary wheel on horizontal exhaust air	406	0	0	406	406	251	251	251	406	251	251	251	251	

Weight of basic units without any options. All weights are given in kg (+/- 5%). Individual weight of a given rooftop is indicated on the rating plate and on the sale's offer

Weight (kg)		E019NN000NN1M	E022NN000NN1M	E027NN000NN1M	E014AH055FM1M	E014AH065FM1M	E014AH075FM1M	E016AH085FM1M	E016AH105FM1M	E019AH066FM1M	E019AH076FM1M	E019AH086FM1M	E019AH106FM1M	E019AH124FM1M
Base unit		-	-	-	1410	1492	1552	1579	1644	1509	1565	1593	1658	166
Base unit without condensing		841	942	986	-	-	-	-	-	-	-	-	-	-

Dimensions (mm)

		E022AH077FM1M	E022AH087FM1M	E022AH107FM1M	E022AH140FM1M	E024AH078FM1M	E024AH088FM1M	E024AH108FM1M	E024AH126FM1M	E024AH141FM1M	E027AH160FM1M	E027AH180FM1M	
LENGTH (mm)	Base unit (frame only without air hood)	4601	4601	4601	5202	4601	4601	4601	5202	5202	5202	5202	
	+ Air hood additional length (fresh or exhaust)	<i>Depends on configuration and options (between 450mm and 612mm). Refer to drawing.</i>											
	+ Vertical extraction EC plug fan	961	961	961	961	961	961	961	961	961	961	961	961
	+ Rotary wheel on vertical exhaust air	588	588	588	588	588	588	588	588	588	588	588	588
	+ Thermodynamic heat recovery on vertical exhaust air	588	588	588	588	588	588	588	588	588	588	588	588
	+ Horizontal extraction EC plug fan	2177	2177	2177	2177	2177	2177	2177	2177	2177	2177	2177	2177
	+ Rotary wheel on horizontal exhaust air	0	0	0	0	0	0	0	0	0	0	0	0
	+ Thermodynamic heat recovery on horizontal exhaust air	0	0	0	0	0	0	0	0	0	0	0	0
	+ Condensing gas burner Standard Vertical	0	0	0	0	0	0	0	0	0	0	0	0
	+ Condensing gas burner High Vertical	235	235	235	235	235	235	235	235	235	235	235	235
	+ Condensing gas burner Standard Horizontal	1713	1713	1713	1713	1713	1713	1713	1713	1713	1713	1713	1713
	+ Condensing gas burner High Horizontal	1713	1713	1713	1713	1713	1713	1713	1713	1713	1713	1713	1713
WIDTH (mm)	Base unit (frame only without air hood)	2270	2270	2270	2270	2270	2270	2270	2270	2270	2270	2270	
	+ Air hood additional width (fresh or exhaust)	<i>Depends on configuration and options (between 441mm and 595mm). Refer to drawing.</i>											
HEIGHT (mm)	Base unit	2275	2275	2275	2275	2275	2275	2275	2275	2275	2275	2275	
	+ Rotary wheel on vertical exhaust air	0	0	0	0	0	0	0	0	0	0	0	
	+ Rotary wheel on horizontal exhaust air	0	0	0	0	0	0	0	0	0	0	0	

Weight of basic units without any options. All weights are given in kg (+/- 5%). Individual weight of a given rooftop is indicated on the rating plate and on the sale's offer

Weight (kg)

	E022AH077FM1M	E022AH087FM1M	E022AH107FM1M	E022AH140FM1M	E024AH078FM1M	E024AH088FM1M	E024AH108FM1M	E024AH126FM1M	E024AH141FM1M	E027AH160FM1M	E027AH180FM1M
Base unit	1601	1682	1761	2049	1653	1734	1812	2022	2118	2163	2197
Base unit without condensing	-	-	-	-	-	-	-	-	-	-	-

Mandatory handling devices

MANDATORY HANDLING DEVICES

Handling slings to guide the unit toward the roof curb

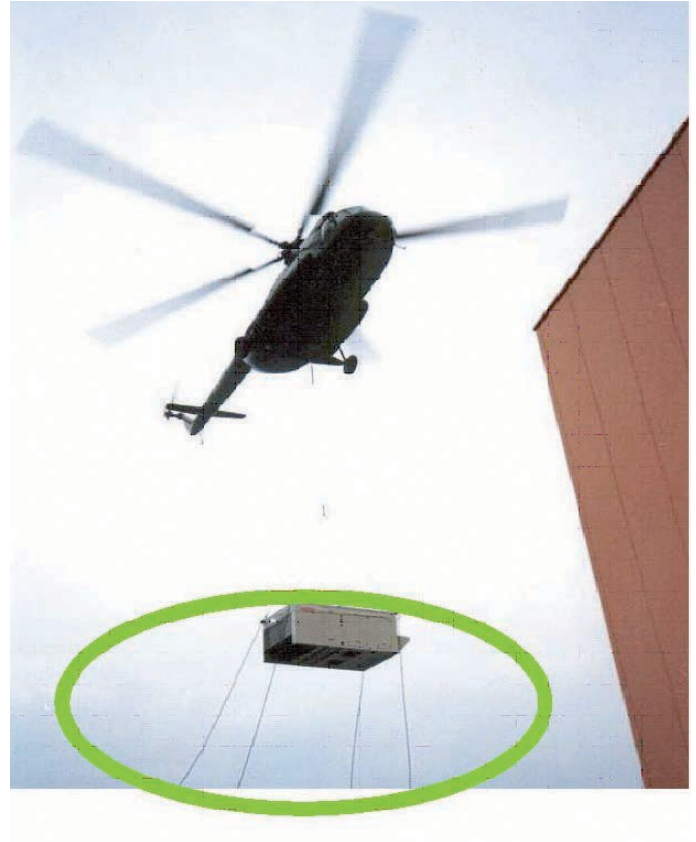

Vacuum lifting beam to position the unit



Handling of the unit with a forklift is absolutely forbidden

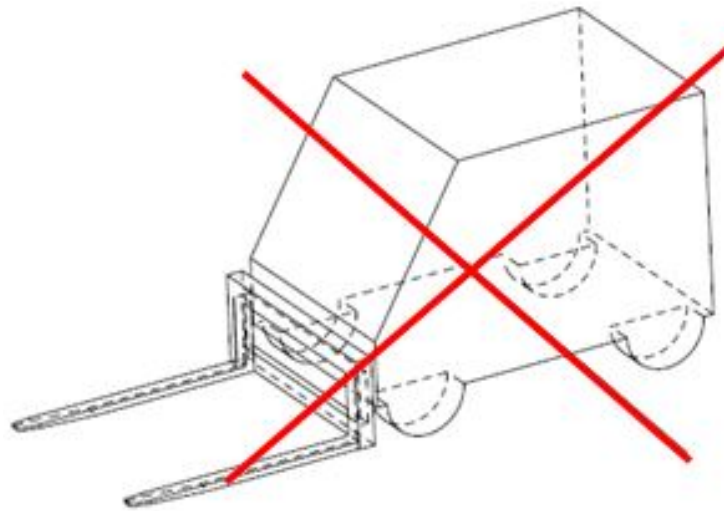

Only lifting the unit with a crane is permitted

Lifting shackles dimensions

Use lifting shackles on each lifting lug located on the base frame of the unit (4 or 6 depending on the unit configuration).
Maximum diameter of the shackle ring shaft = 20 mm.

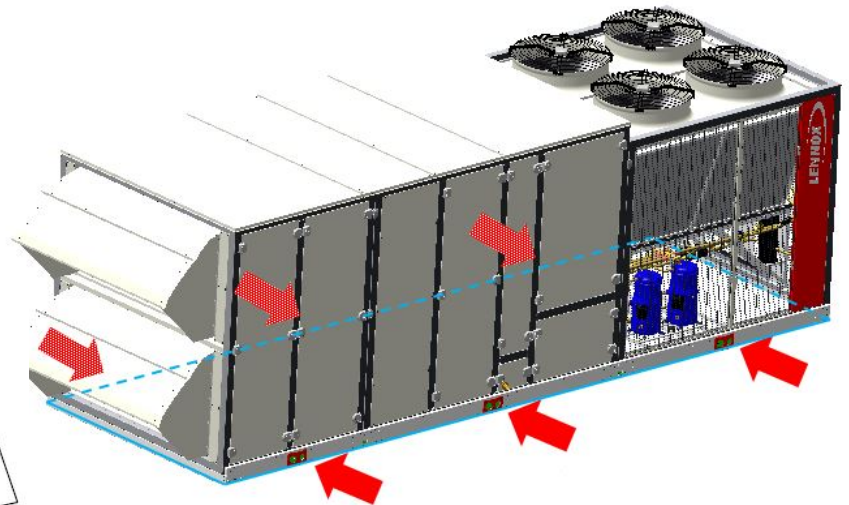
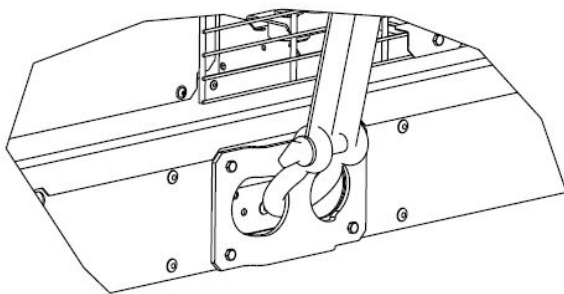
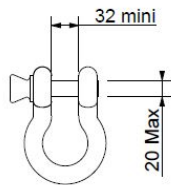

Lifting belts/straps length

The unit must be lifted using spacing beams to avoid the belts damages to the casing (2400mm).
The belts/straps length must respect following instructions:

- In case of a unit with 4 points, see picture below :

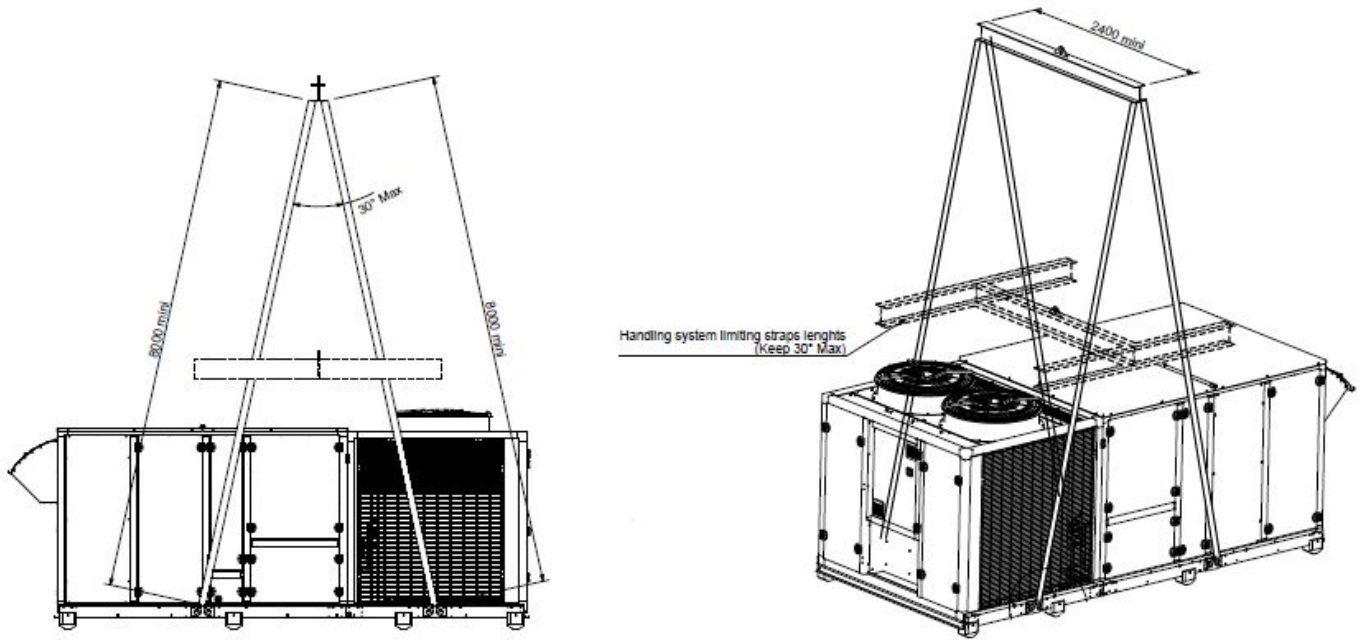

- In case of a unit with 6 points, see picture below.
The use of a chain hoist is mandatory.

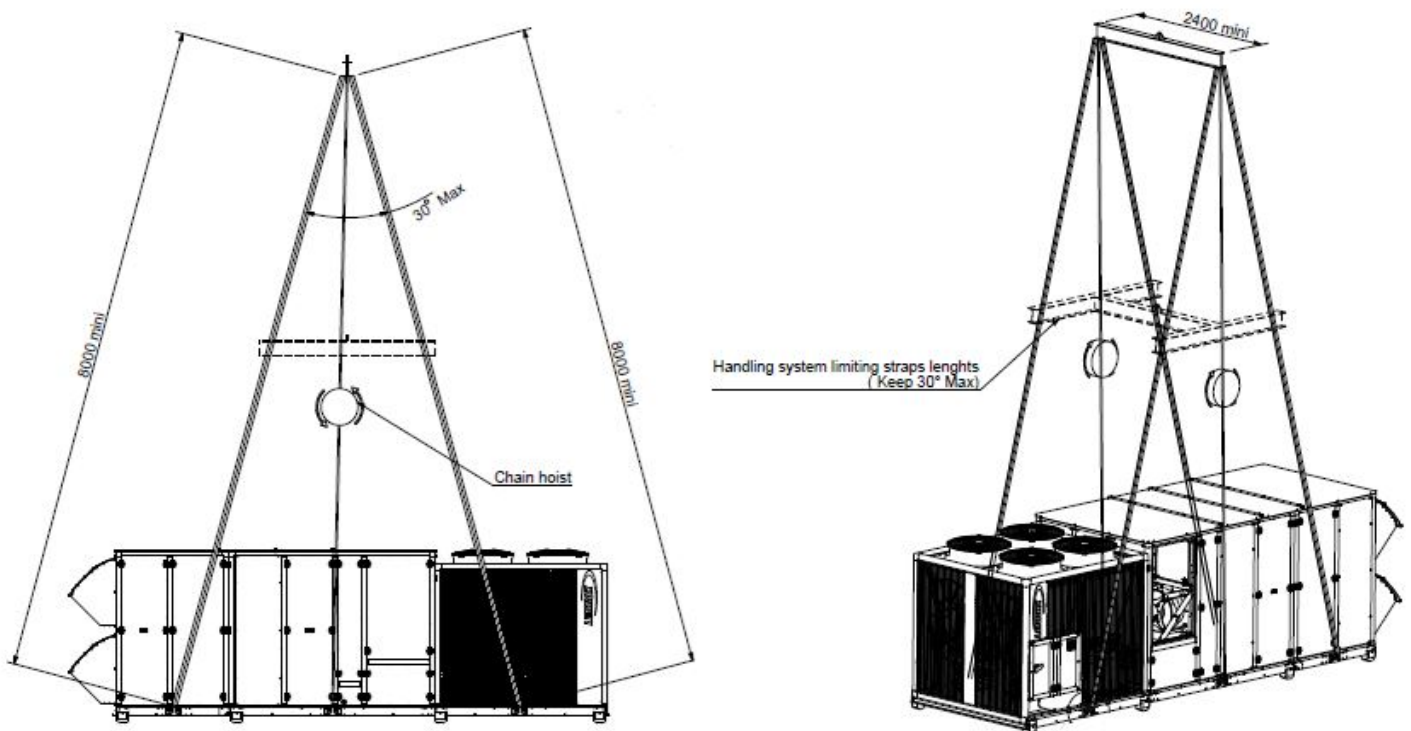

Minimum clearance around the unit installation

Figures below show the required clearances and service access around the unit. Please take care that the clearances depend on the unit size (Units above 125kW need more clearance for the outdoor coils service).

Units below 125kW

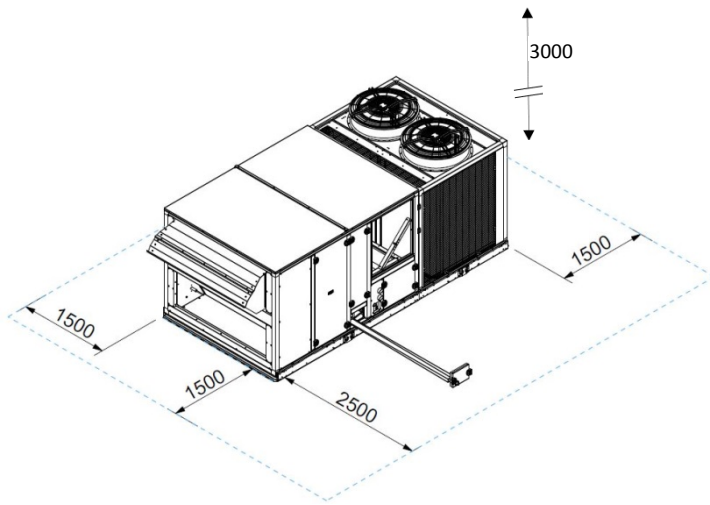

Units above 125kW

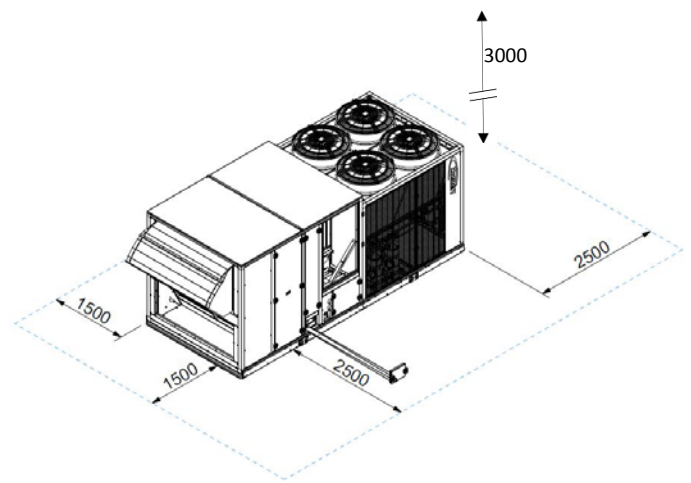

IMPORTANT note for unit clearances

- Ensure the fresh air inlet does not face prevailing wind direction.
- If machine is including gas burner, minimum clearance around the unit must be at least 8 m to allow a proper gas flue dilution. If not possible, the fresh air intake must be ducted at least 8 m away from the gas burner exhaust.
- In case of extraction option, it is recommended to duct fresh air intake.
- It is also important to respect a minimal clearance of 3 meters above of the unit, to allow a good operation of the outdoor fans.

On receipt of new equipment please check the following points.

It is the customer's responsibility to ensure that the products are in good working order:

- The exterior has not been damaged in any way.
- The lifting and handling equipment are suitable for the equipment and comply with the specifications of the handling instructions enclosed here-in.
- Accessories ordered for on-site installation have been delivered and are in good working order.
- The equipment supplied corresponds to the order and matches the delivery note.

If the product is damaged, exact details must be confirmed in writing by registered post to the shipping company within 48 hours of delivery (working days). A copy of the letter must be addressed to LENNOX and the supplier or distributor for information purposes. Failure to comply will invalidate any claim against the shipping company.

Rating plate

The rating plate provides a complete reference for the model and ensures that the unit corresponds to the model ordered. It states the electrical power consumption of the unit on start-up, its rated power and its supply voltage. The supply voltage must not deviate beyond +/- 5 %. The start-up power is the maximum value likely to be achieved for the specified operational voltage. The customer must have a suitable electrical supply. It is therefore important to check whether the supply voltage stated on the unit's rating plate is compatible with that of the mains electrical supply. The rating plate also states:

- year of manufacture
- weight of the unit
- type of refrigerant used + GWP: Global warming potential
- required charge for each circuit
- operating Pressure min/max
- operating Temperature min/max

CE marking : 3 possible cases

- CE
- CE0038
- Absence of CE marking

LENNOX LGL FRANCE S.A.S ZI Les Meurières 69780 Mions France		CE 0038					
Unit type: E024AH141FM1M							
Serial Nr : 289805_1 1/1							
	Voltage (V)	Phase (Ph)	Frequency (Hz)	Current (A)			
Elec Supply	400	3	50	Nominal	Starting		
Elec Aux.	24	1	50	130,7	201,8		
				Min	Max		
				LP	HP		
Pressure (PS) (bar)				-1	-1		
Temperature (TS) (°C)				-20	-20		
Storage Temperature (°C)				-30	50		
LP : Low Pressure side / HP : High Pressure side							
Nominal Capacity (kW)		Ref Charge (kg)				Dates	
Cooling	Heating	C1	C2	C3	C4	Prod.	Test
140,5	141,6	21	22	0	0	2017	07/09/2017
Fluid		Fluid Group				Weight (kg) +/-5%	
R410A GWP 2088		2				3821	
This product is used for Air Conditioning. Contains fluorinated greenhouse gases covered by the Kyoto protocol. Hermetically sealed.							

Storage

When units are delivered on site they are not always required immediately and are sometimes put into storage. In the event of medium to long-term storage, we recommend the following procedures:

- Ensure that there is no water in the hydraulic systems
- Keep the heat exchanger protection if any.
- Keep protective plastic film in position.
- Ensure the electrical panels are closed.
- Keep all items and options supplied in a dry and clean place for future assembly before using the equipment.
- Store the unit on an appropriate place (flat surface).
- Storage temperature must be respected according to the information given on the rating plate

Maintenance access

With the new easy lock system integrated in eNeRGy, we can have different possibilities of panel opening, making more easy maintenance operations.

Panels can be opened rightwards, leftwards and they can also be dismantled completely, by removing all the lockers.

The lockers are equipped with a locking system (lock/unlock with a tool).

After commissioning, all the panels must be closed and locked.

After any maintenance operation, all the panels must be closed and locked.



The lockers can also be adjusted in vertical position in order to facilitate the opening/closing of all panels once the unit is definitively installed on its final position. A freedom of +/-5 mm is given to all lockers.

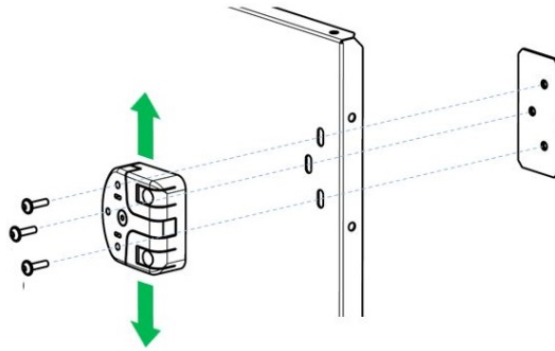

It's recommended to adjust the lockers position in case of difficulty by opening/closing a panel. This operation is possible by loosening the 3 screws. Be careful: never totally loosen the 3 screws simultaneously. A maximum of 2 revolutions per screw is enough to setup the lockers. After adjustment of the locker position, the 3 screws must be tight again.



During this operation, it's important to keep a constant peripheral clearance (4mm) around the panel:



Condensate drains

The condensate drains are not assembled when delivered and are stored in the electrical panel with their clamping collars. To assemble them, insert them on the condensate tray outlets and use a screwdriver to tighten the collars. The drains must be installed in vertical position.

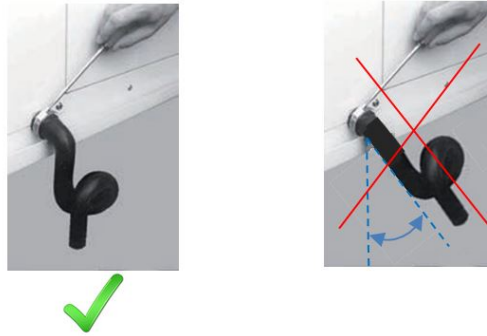

For the thermodynamic heat recovery circuit it's not necessary to add a separated condensate drain on the outdoor coil.

Preliminary checks

Before installing the equipment, the following points **MUST** be checked:

- Is there sufficient space for the equipment?
- Is the surface on which the equipment is to be installed sufficiently solid to withstand its weight? A detailed study of the frame must be made beforehand. The surface on which the equipment is to be installed must be flat. (See next paragraph)
- Do the supply and return ductwork openings excessively weaken the structure?
- Are there any obstructing items which could hinder the operation of the equipment?
- Does the electrical power available correspond to the equipment's electrical specifications?
- Is drainage provided for the condensate?
- Is there sufficient access for maintenance?
- Installation of the equipment could require different lifting methods which may vary with each installation (helicopter or crane). Have these been evaluated?
- Ensure that the unit is installed in accordance with the installation instructions and local applicable codes.
- Check to ensure that the refrigerant lines do not rub against the cabinet or against other refrigerant lines.

In general, make sure no obstacles (walls, trees or roof ledges) are obstructing the duct connections or hindering assembly and maintenance access.

Installation requirements

The surface on which the equipment is to be installed must be clean and free of any obstacles which could hinder the flow of air to the condensers:

- Uneven surfaces are prohibited. The surface must be flat and respect a maximal flatness of 0.5mm per linear meter (in both directions length and width). See below an example with 6000 mm long unit:

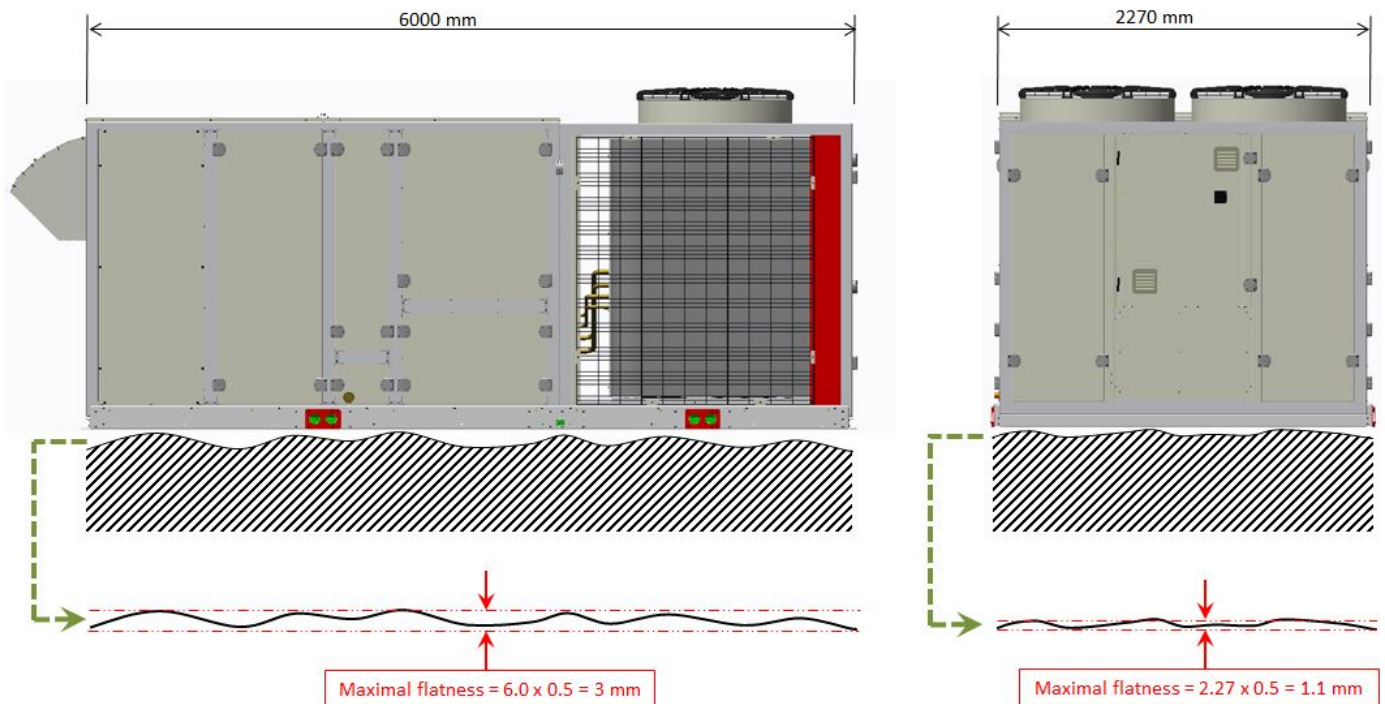

- The surface must support the unit base frame which is composed of two parallel rails:

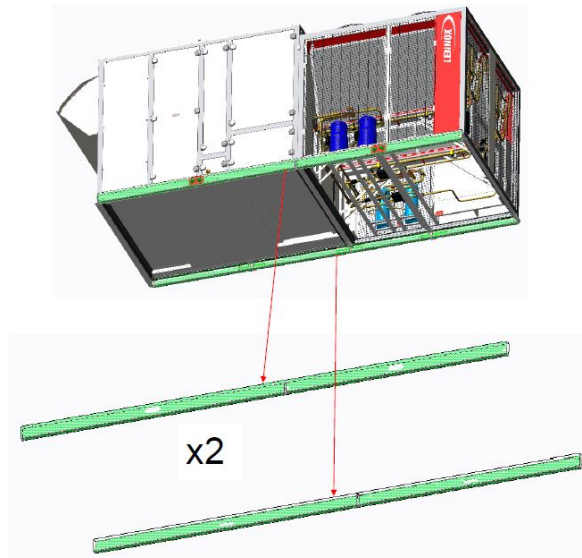

The surface must support continuously the entire area of these 2 rails (no rubber pad, no spring, no block...). See bottom view of the unit:

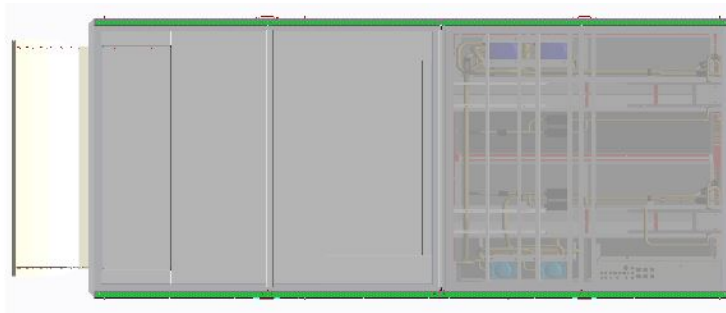

In case of installing the unit on dedicated structure (for example a specific metallic frame structure), the structure must be compliant with the unit base frame design and dimensions (width is the same for all units; length depends on the unit so refer to 2D drawing available):

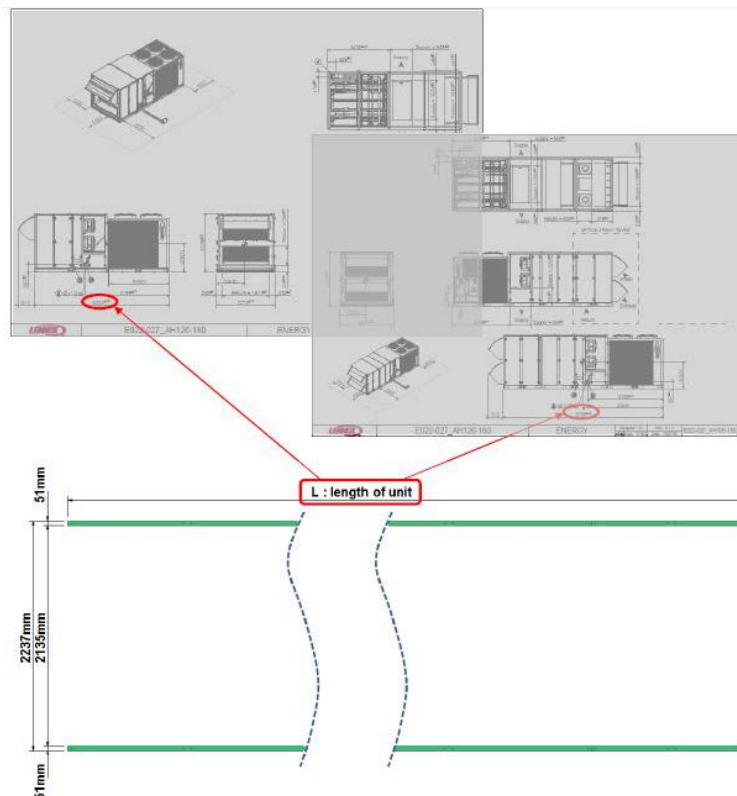

- Avoid installing two units side by side or close to each other as this may restrict the airflow to the condensers, and could limit the access for maintenance purposes.

Before installing a packaged rooftop unit it is important to understand:

- The direction of prevailing winds
- The direction and position of air flows.
- The external dimensions of the unit and the dimensions of the supply and return air connections.
- The arrangement of the doors and the space required to open them to access the various components.

Connections

- Ensure that all the pipe-work crossing walls or roofs are secured, sealed and insulated.
- To avoid condensation problems, make sure that all pipes are insulated according to the temperatures of fluids and type of rooms.

NOTE: The packaging protection fitted on the finned surfaces must be removed prior to start up.

Example of non-adjustable roofcurb without condensing unit

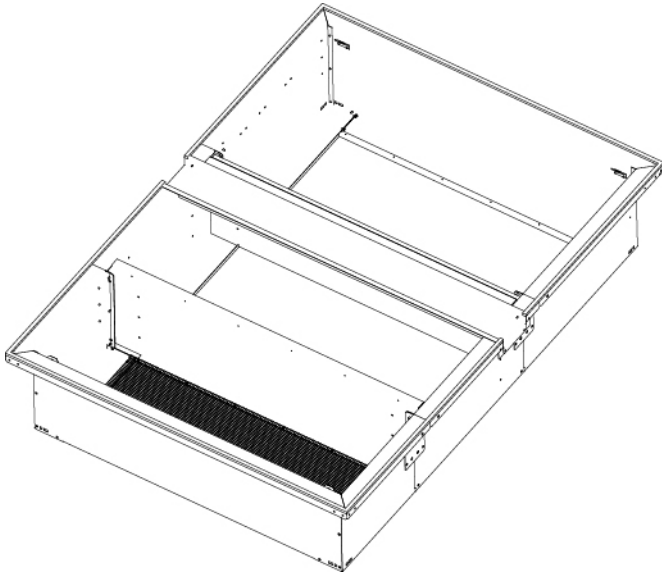

Example of adjustable roofcurb without condensing unit

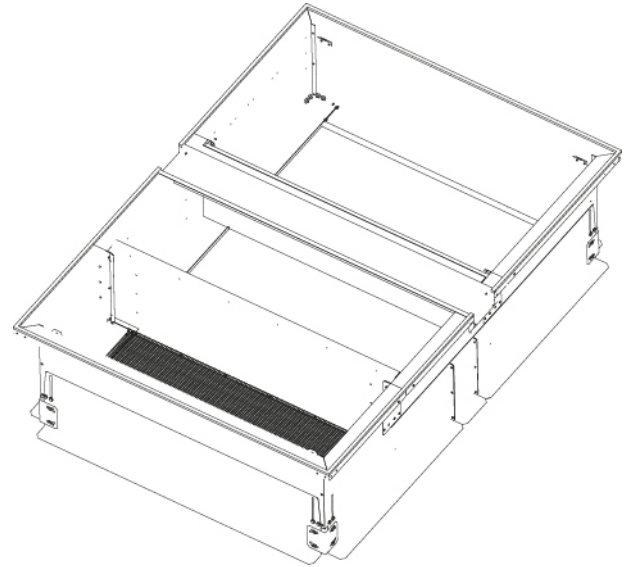

Example of non-adjustable roofcurb with condensing unit

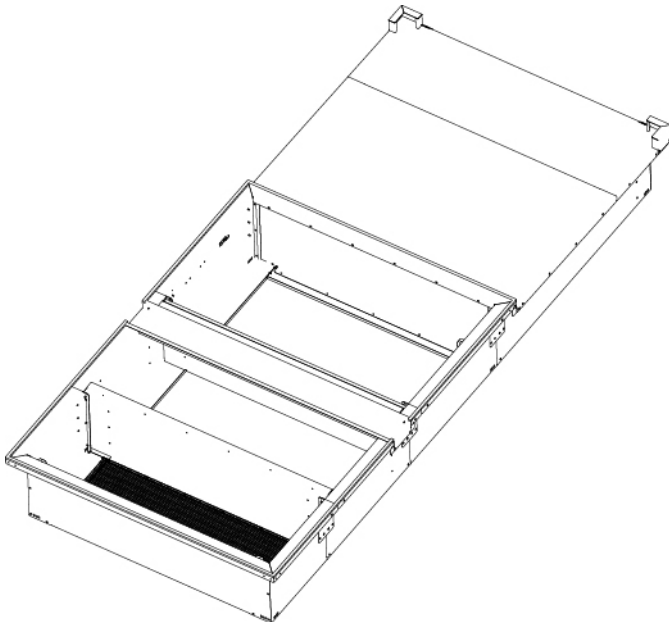

Example of adjustable roofcurb with condensing unit

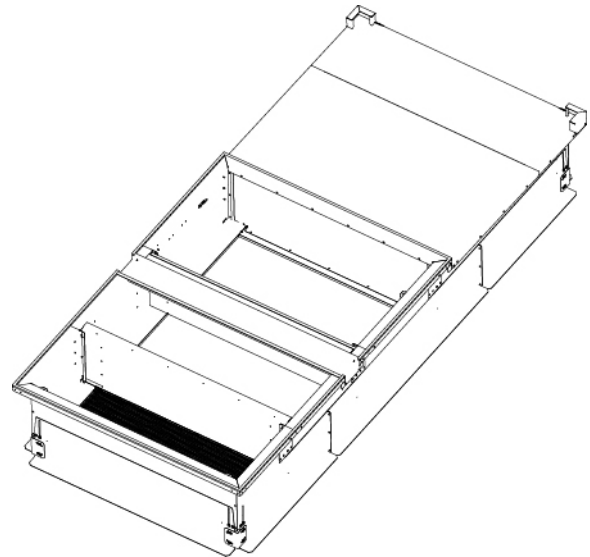

WARNING : all the roofcurb must be strongly secured to the ground
The contact to the ground must be realized with the entire contact area of the roofcurb (no discontinuous contact).

CAUTION

- Installation of the unit and accessibility must be compliant with the local regulations. Ensure that all access equipments allow maintenance operation in safety (electrical cabinet, main switch, panels, filter, refrigerant circuit...)

This recommendation is valid for installations in general and in particular for return and curbs.

- It's advised to fix curbs and roofcurbs to the unit.

Roof opening dimensions

The roof opening dimensions & maximum slope are defined according mechanical drawings.

Levelling adjustable roofcurbs

The levelling operation must be done prior to put the unit on it.

Above all, ensure that all the adjustable returns are facing outward. They could be turned inside-out for transport.

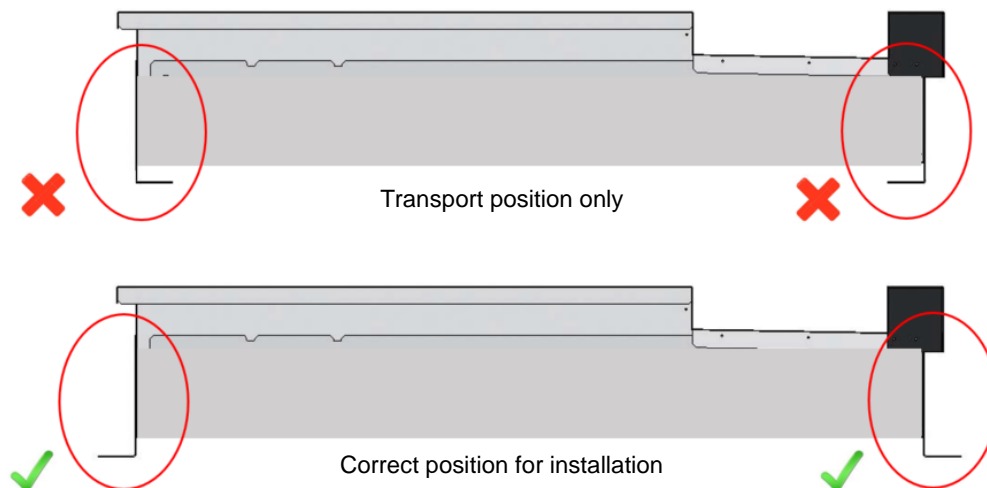

Place the roof mounting frame on the trimmer beam by first lining up the inlet and the outlet opening.

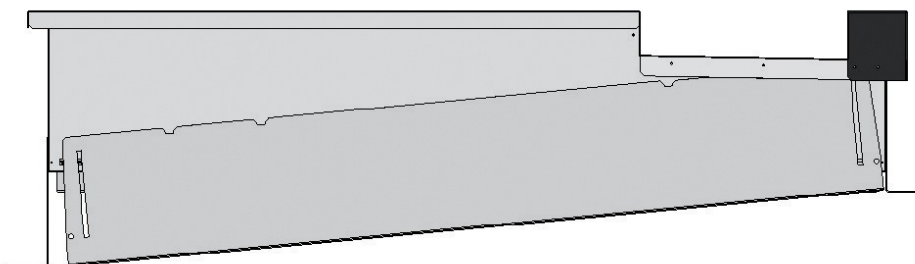

After levelling the frame, secure the adjustable returns on the trimmer.

IMPORTANT NOTE: Securing the roofcurb

When the roofcurb is correctly positioned, it is essential to secure the assembly with a disconnected stitched welded seam (20 to 30 mm every 200 mm) or self-taping screws (every 200mm) along the outside.

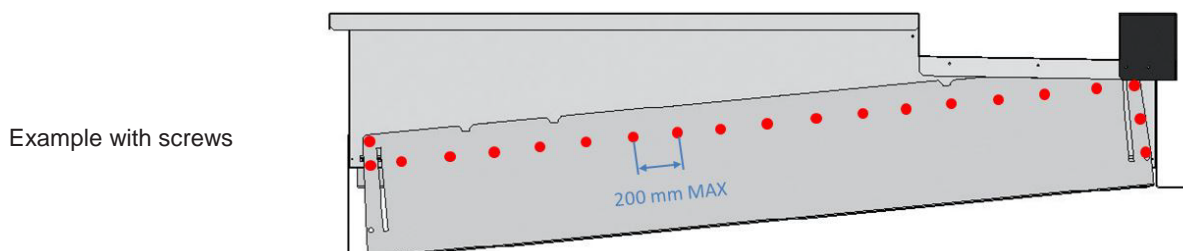
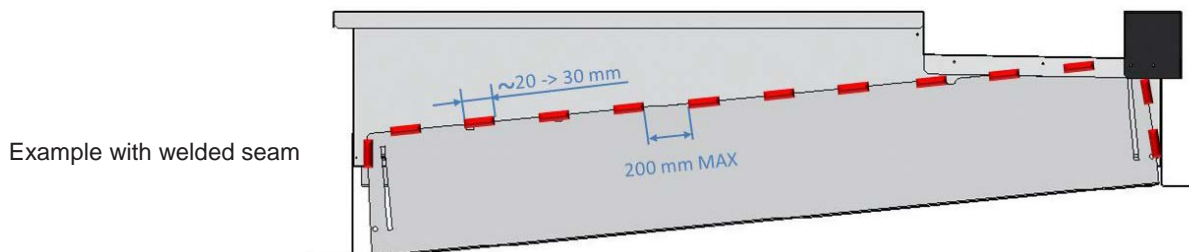

Curbing and flashing

Check that the insulation is continuous, counter flash and seal around the frame as shown.
 CAUTION: To be effective, the upstream must end below the drop edge.

Pipes (gas, water...) and electrical cables must not cross the roofcurb.

Before installing the equipment, make sure that seals are not damaged and check that the unit is secured to the mounting frame. Once in position, the bottom of the equipment must be horizontal. The installer must comply with local authority standards and specifications.

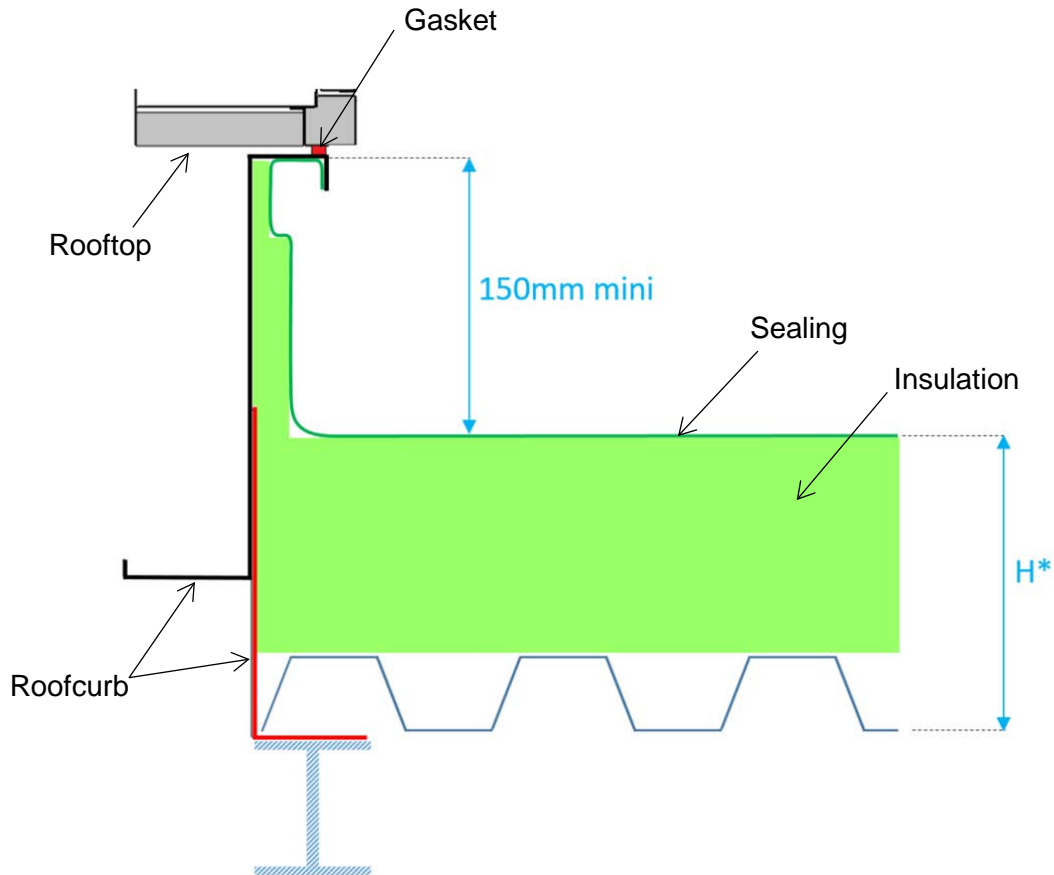

* Check that the roofcurb height is enough to respect a sealing height of 150mm minimum (French DTU 43.3) considering the building specifications : geometry of the roof, material and thickness of the insulations and other protection layers, slope of the roof...).

IMPORTANT note: This operation must be realised prior to put the machine on the roofcurb

Positioning the rooftop on roofcurb (adjustable or non-adjustable)

IMPORTANT note: Prior to put the machine, make sure to put a polyethylene gasket on the roofcurb upper flange side (must be delivered in the roofcurb package).

This gasket must be put only on the external perimeter of the roofcurb and around the supply and return section

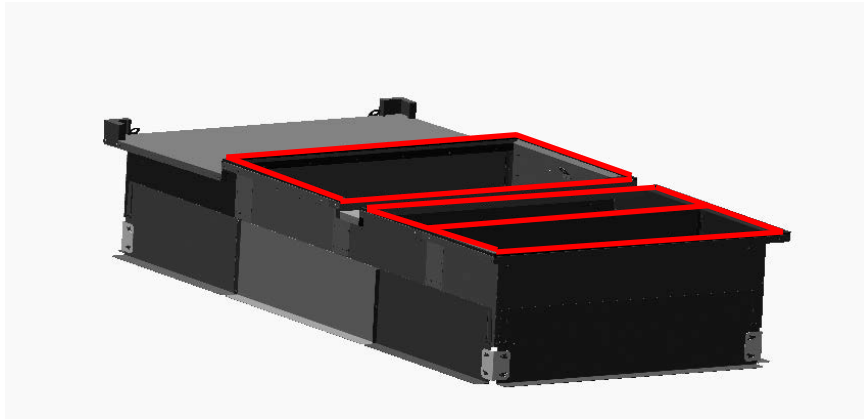

During the installation of the unit on the roofcurb, it's important to keep the unit in horizontal position or with the treatment box slightly downwards. It will make the positioning of the return and the supply easier.

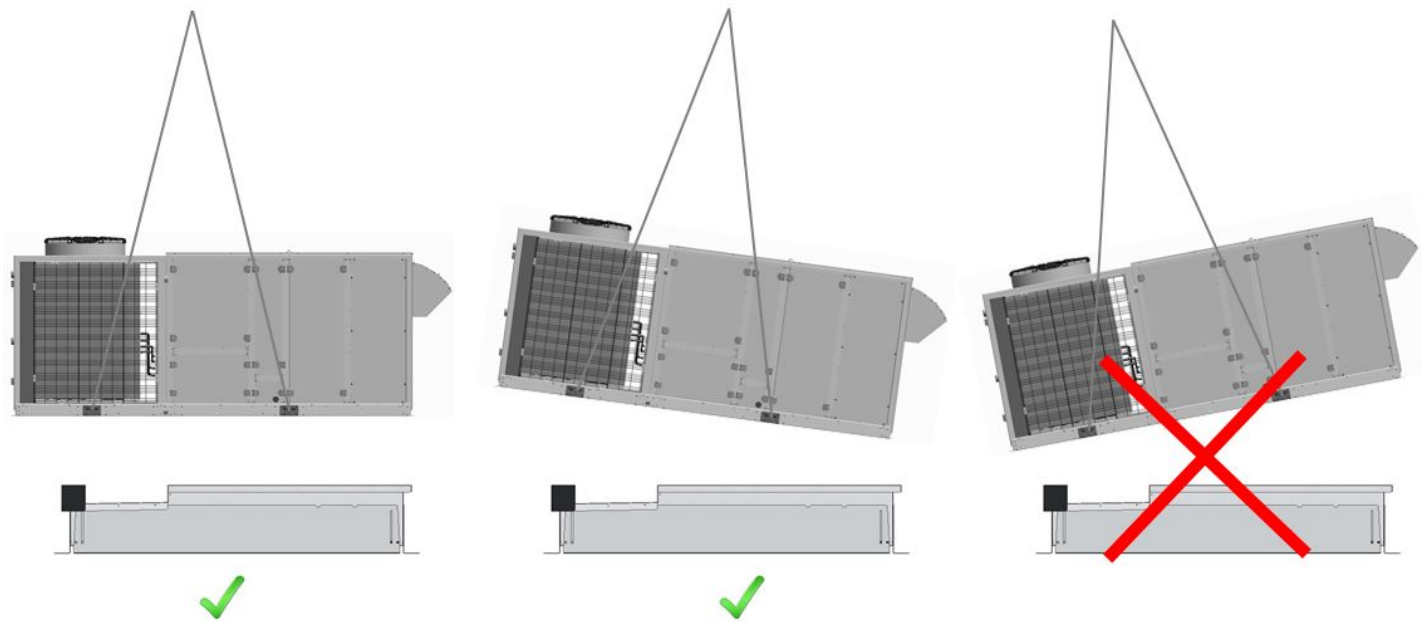

Recommendations for ducts connections

Example of vertical supply:

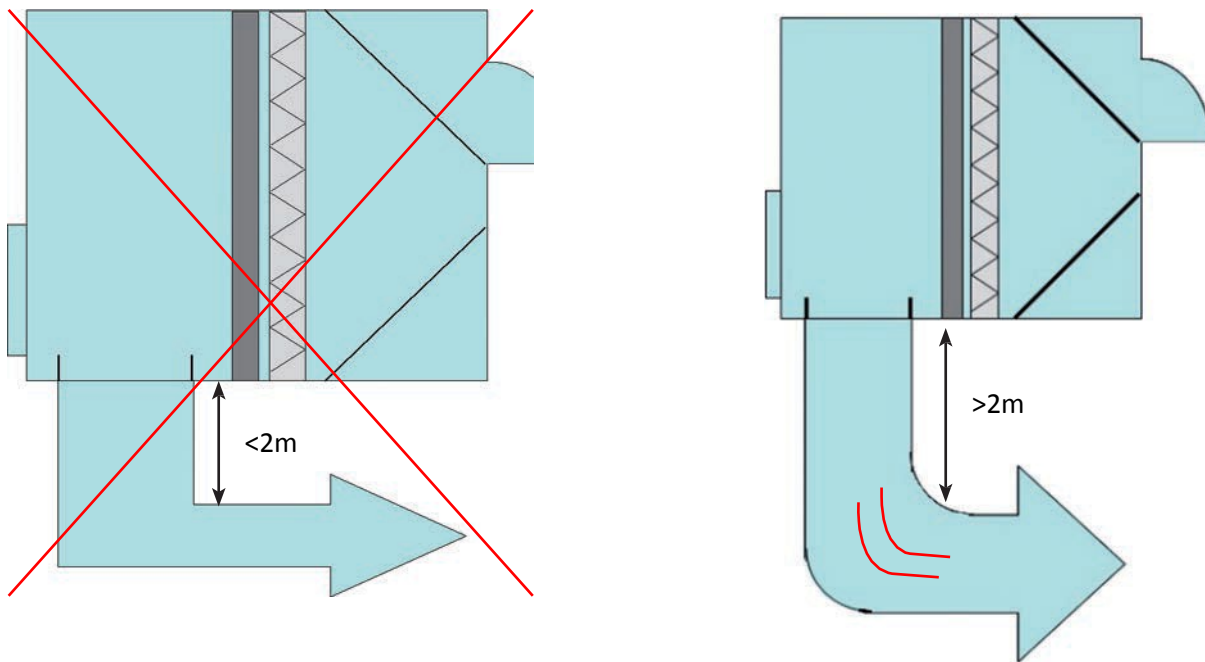

This rule also applies to horizontal supply configurations.

Ducting connection details

The supply and return air ducts can be secured to the flanges at the bottom of the roofcurb. Any ducting weight above 100 kg must be fixed independently to other building frames.

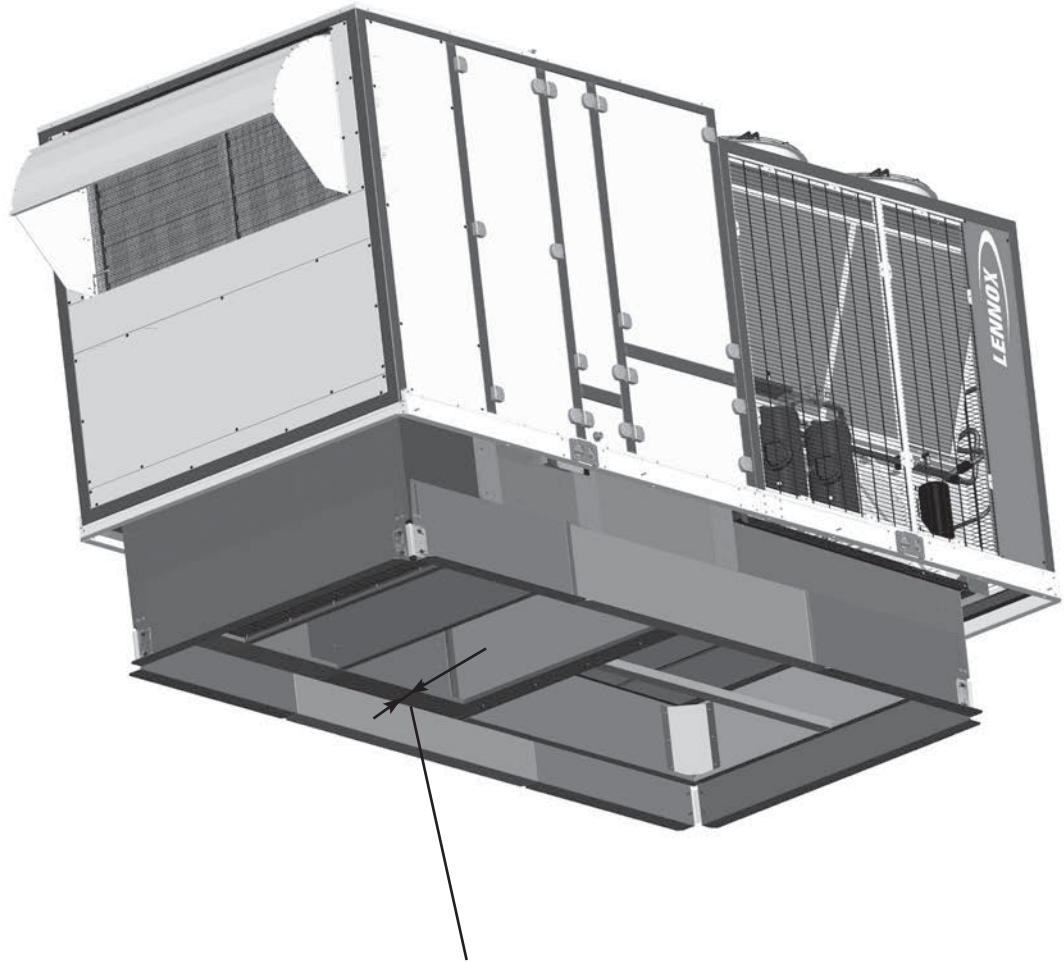

Distance for duct connection: 150 mm

Main Switch Connection

The details of the electrical connection are explained in the table below, depending on the main switch type (main switch type is given in the electrical file delivered with the unit):

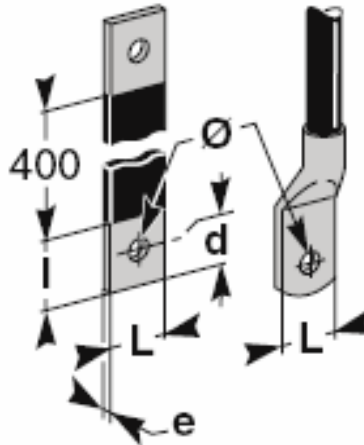

Type (QG1)	Reference (QG1)	Bar or Terminal Copper or Aluminium (mm)	Torque (Nm)	Cable max (mm ²) (OPTION)
INS 125	28910	l: 15 L: ≤ 21 d: ≤ 10 Ø: ≥ 6.2 e: ≤ 2 à 6.4	14 for cable 8 for bar or Terminal	95 (copper)
INS 160	28912			
INS 250	31106	l: d+10 L: ≤ 25 d: ≤ 10 Ø: ≥ 10 e: ≤ 6	15	185 (aluminium)
INS 400	31110	l: d+10 L: ≤ 32 d: ≤ 15 Ø: ≥ 103 3 ≤ e ≤ 10	50	300 (aluminium)
INS 630	31114			

Customer power cable inlet & BUS inlet

One specific plate is located at the bottom of the electrical cabinet for the power cable inlet. This bottom plate should be cut and adapted to cable diameter. It's important to use a cable-seal to ensure the tightness of the electrical cabinet. To facilitate this operation this plate is removable; it's important to put it back in its initial position.

For the BUS connection, a lateral plate is available on the side of the electrical cabinet. It's important to use the cable-seal delivered on this plate

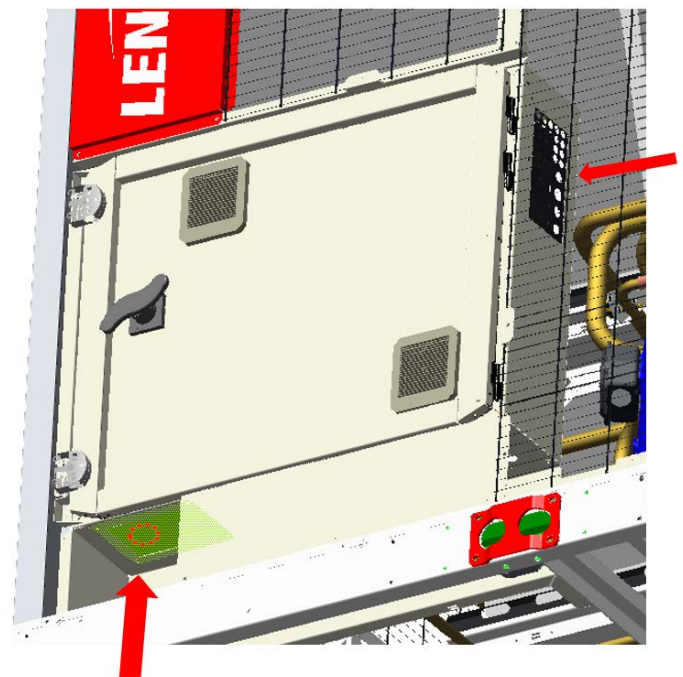

CO2 or Advanced control pack Sensor

The device can be installed in dry surroundings (IP20) by screws on the wall surface or on the standard flush mounting box. The recommended installation height is 150...180 cm.

The device position should be selected carefully. All the error factors that can affect to the measurements should be eliminated as well as possible. The following list defines the typical measurement error factors.

- direct sun light
- occupant proximity
- air flow coming from windows or doors
- air flow coming from ventilation nozzles
- air flow coming from the flush mounting box
- differential temperature caused by external wall

NOTE: CO2 measurement causes a current peak to the supply voltage. This can produce an error to the analogue outputs when using long and thin cables. It is recommended to increase the wire cross section area in long cable situations (e.g. by using four-wire connection) to ensure reliable measurement signal.



Wiring

WARNING: Device wiring and commissioning can only be carried out by qualified professionals. Always make the wirings while the power is switched off.

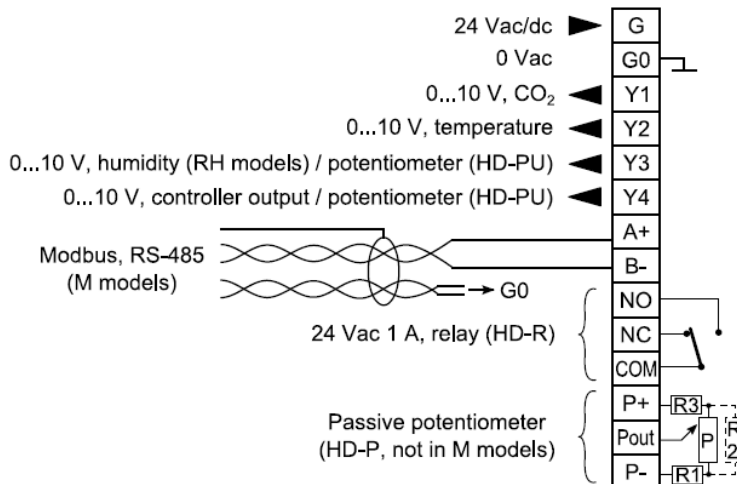

HEAT RECOVERY - GENERAL DESCRIPTION

Heat recovery modules have following interests:

- In winter season and heating mode, the heat in the extract air is exchanged with the fresh air;
- Conversely, in summer season and cooling mode, the heat of the fresh air is transferred to the extract air.

There are 2 types of heat recovery modules integrated in the unit (as option):

- Recovery of the heat from the extracted air through a Rotary Wheel.
- Thermodynamic heat recovery module (TRMO), included in the machine. Its main interests are:
 - A variable fresh air rate from 25 to 100%,
 - A high COP in winter when pre-heating the fresh air due to a favourable evaporating temperature, especially with high air flow rate;
 - A high EER in summer when pre-cooling the fresh air due to a favourable condensing temperature, especially with high air flow rate.

For those reasons, TRMO will be more suitable than Rotary Wheel in areas where the difference between indoor temperature and outdoor temperature is low. For example, in Mediterranean areas, where winter temperatures are not very cold or summer temperatures are not very high.

Rotary Wheel and TRMO will be delivered totally assembled in the unit (as option). All wire connections are factory made.

Rotary wheel:

Vertical return

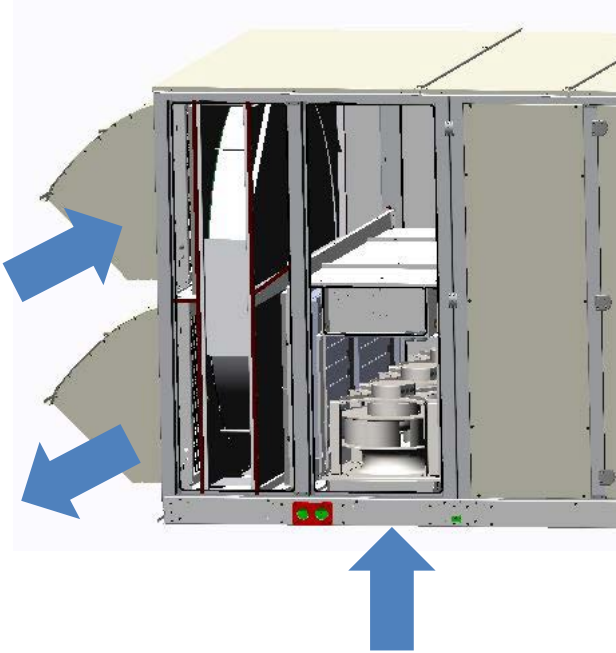

Horizontal return

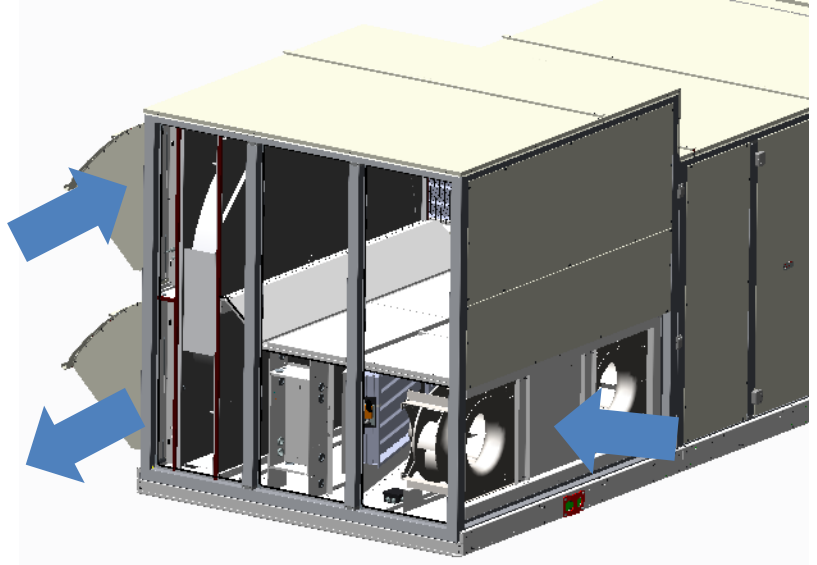

Thermodynamic heat recovery module (TRMO)

Frigorific components access:

Compressors are located in the dedicated recovery module

Vertical return

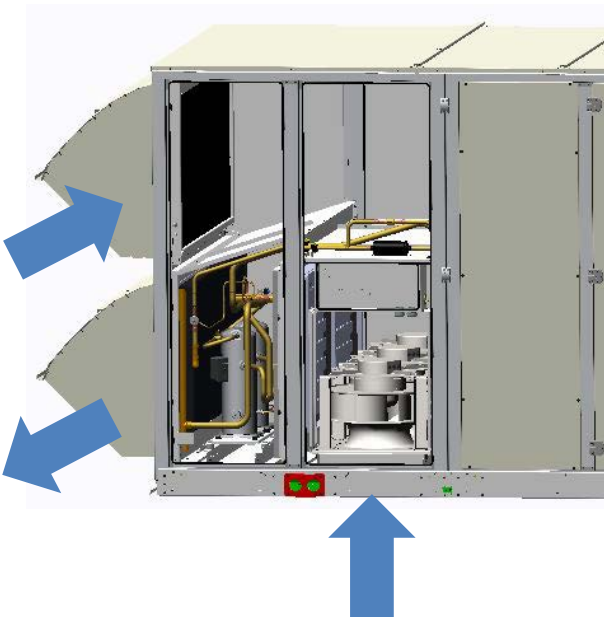

Horizontal return

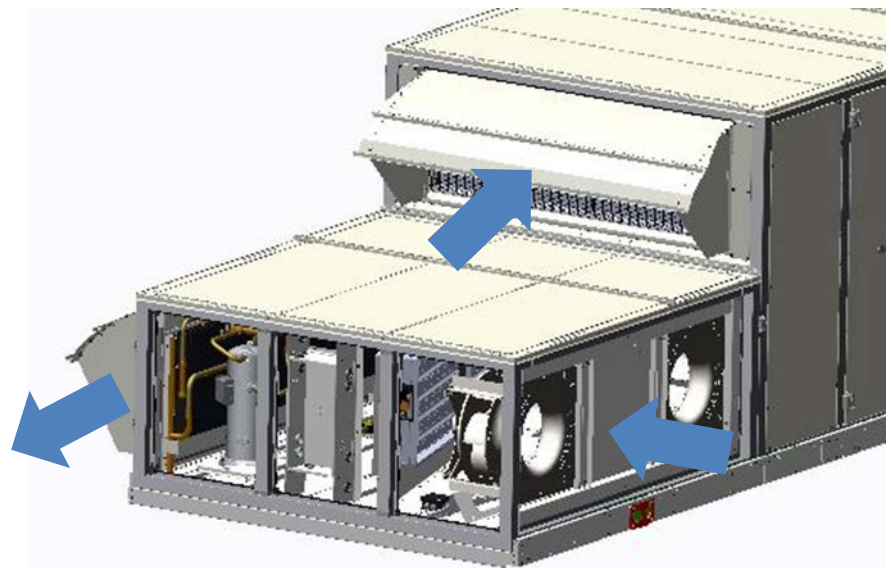

SERVICE MANUAL

Ref : eNeRGy-IOM-1711-E

EU CONFORMITY DECLARATION TEMPLATE	33
ECODESIGN DATA SHEET TEMPLATE	34
COMMISSIONING	
Operating limits	35
Casing Condensation Risk	38
Before turning on the power	39
Wire connection tightness checks	39
CLIMATIC™ configuration	40
FRESH/EXHAUST AIR HOODS	42
FILTERS	43
REFRIGERATION CIRCUIT	45
HOT AND COLD WATER COILS	47
RECOVERY WATER COIL	48
ELECTRICAL HEATER	49
ELECTRICAL PREHEATER	50
GAS BURNER	51
SERVICE DIAGNOSTIC	61
WARRANTY	64
MAINTENANCE PLAN	66
COMMISSIONING RECORD SHEET	70
REFRIGERANT TRANSACTIONS LOGBOOK	72



LGL France SAS
ZI de LONGVIC – BP 80
21602 LONGVIC Cedex – France
Téléphone : +33 (0)3 80 77 41 41
Fax : +33 (0)3 80 66 66 35



**DECLARATION DE CONFORMITE UE
EU CONFORMITY DECLARATION**

LGL France SAS - ZI Les Meurières - 69780 Mions – France

La société soussignée certifie sous sa seule responsabilité que les fabrications de roof top (ensembles sous pression) désignés par les types suivants :
The company hereby declare, under its own responsibility, that roof top (pressure equipment constituting the assembly) which are designated by:

Gamme / Range : ENERGY
Type / Type : XXXXXXXXXXXX
N° d'affaire / Project Number : XXXXXXXX

Qui contiennent des fluides frigorigènes classés en groupe 2 (R407C ou R410A),
Which are containing refrigerating fluids classified in group 2 (R407C or R410A),

1. Sont conformes aux dispositions de la Directive « Equipements sous pression », 2014/68/UE
Is in compliance with the requirements of « Under pressure equipments » directive, 2014/68/EU.

Module d'évaluation Evaluation Module: H
0038/PED/FQA4002775/A

Organisme notifié Notified body: Lloyd's register verification limited (0038)
71 fenchurch Street, London, EC3M 4BS UK

2. Sont conformes aux dispositions de la Norme EN378-2016
Are in compliance with the requirements of EN378-2016

3. La déclaration est conforme à la législation d'harmonisation de l'Union
The declaration is in conformity with the relevant Union harmonisation legislation

4. Sont conformes aux dispositions de la Réglementation - Are in compliance with the requirements of

- UE 517/2014 « F-gaz », relatif aux gaz à effet de serre fluorés - EU 517/2014 « F-gas », on fluorinated green-house gases.
- CE 1005/2009 relatif à des substances qui appauvrissent la couche d'ozone - EC 1005/2009 on substances that deplete the ozone layer

5. Sont conformes aux dispositions de la directive - Are in compliance with the requirements of

- « Machines », 2006/42/CE - « Machinery », 2006/42/EC
- « CEM », 2014/30/UE - « EMC », 2014/30/EU
- « Basse Tension » 2014/35/UE, « Low voltage », 2014/35/EU
- « RoHS », 2011/65/UE, « RoHS », 2011/65/EU
- « DEEE », 2012/19/UE, « WEEE », 2012/19/EU
- « Ecoconception », 2009/125/CE, « Ecodesign », 2009/125/EC

Signé par et au nom de / Signed for and on behalf of : LGL France SAS

Date : XX/XX/XXXX

XXXXX XXXXXX
Directeur Qualité Europe
European Quality Director

Nom de la personne autorisé à constituer le dossier technique:
Name of the person authorized to establish the technical file:

Nom / Name: XXXXXX XXXXXXX
Directeur R&D HVAC & Réfrigération EMEA
Engineering Director HVAC & Refrigeration EMEA
Adresse / Address : LGL France SAS, ZI les Meurières, 69780 Mions, France



Information requirements for heat pumps (EU 2016/2281)

Model:	XXXXXXXX
Outdoor side heat exchanger of heat pump:	Air
Indoor side heat exchanger of heat pump:	Air
Equipped with a supplementary heater:	No
Driver of compressor:	Electric motor

Parameters declared for the average heating season, parameters for the warmer and colder heating seasons are optional.

Item	Symbol	Value	Unit	Item	Symbol	Value	Unit
Rated heating capacity	$P_{rated,h}$		KW	Seasonal space heating energy efficiency	η_{sh}		%
Declared heating capacity for part load at indoor temperature 20 °C and outdoor temperature T_j				Declared coefficient of performance for part load at given outdoor temperatures T_j			
$T_j = -7\text{ °C}$	P_{dh}		KW	$T_j = -7\text{ °C}$	COP_d		-
$T_j = +2\text{ °C}$	P_{dh}		KW	$T_j = +2\text{ °C}$	COP_d		-
$T_j = +7\text{ °C}$	P_{dh}		KW	$T_j = +7\text{ °C}$	COP_d		-
$T_j = +12\text{ °C}$	P_{dh}		KW	$T_j = +12\text{ °C}$	COP_d		-
T_{div} = bivalent temperature	P_{dh}		KW	T_{div} = bivalent temperature	COP_d		-
T_{ox} = operation limit	P_{dh}		KW	T_{ox} = operation limit	COP_d		-
For air-to-water heat pumps: $T_j = -15\text{ °C}$ (if $T_{ox} < -20\text{ °C}$)	P_{dh}	—	KW	For water-to-air heat pumps: $T_j = -15\text{ °C}$ (if $T_{ox} < -20\text{ °C}$)	COP_d	—	-
Bivalent temperature	T_{div}		°C	For water-to-air heat pumps: Operation limit temperature	T_{ox}	—	°C
Degradation coefficient (**)	C_{dh}	0.25	—				
Power consumption in modes other than 'active mode'				Supplementary heater			
Off mode	P_{off}		KW	Back-up heating capacity (*)	e_{bu}		KW
Thermostat-off mode	P_{to}		KW	Type of energy input		-	
Crankcase heater mode	P_{ck}		KW	Standby mode	P_{sh}		KW

Other items

Capacity control	staged			For air-to-air heat pumps: air flow rate, outdoor measured	—		m ³ /h
Sound power level, indoor/outdoor measured	L_{WA}	/	dB(A)	For water/brine-to-air heat pumps: Rated brine or water flow rate, outdoor heat exchanger	—	—	m ³ /h
Emissions of nitrogen oxides (if applicable)	NO_x (***)	—	mg/kWh fuel input GCV				
GWP of the refrigerant		2088	kg CO ₂ e (100 years)				
Contact details	Lennox EMEA - ZI Les Meunières - BP71 - 69780 MIONS - FRANCE						

(*) If C_{dh} is not determined by measurement then the default degradation coefficient of heat pumps shall be 0,25.
 (***) From 26 September 2018.

Where information relates to multi-split heat pumps, the test result and performance data may be obtained on the basis of the performance of the outdoor unit, with a combination of indoor unit(s) recommended by the manufacturer or importer.

WARNING: all the components must be installed by a qualified engineer

OPERATING LIMITS

Prior to any operation, please check the operation limits of the unit. These tables will give you all necessary information concerning the operating envelop of the unit.

WARNING: It is very important ensure the units operate well inside these envelopes.

Fix Speed Compressors

	E014AH055F	E014AH065F	E014AH075F	E016AH085F	E016AH105F	E019AH066F	E019AH076F	E019AH086F	E019AH106F	E019AH124F
Envelopes in °C										
Cooling mode operating limits given for steady state running condition with noted temperature condition										
Max. outdoor air temperature at indoor air temp. 27°C DB / 19°C WB	48									
Max. outdoor air temperature at Min indoor air temp.DB / 47%HR	48									
Max outdoor air temperature with unloading	49,5	51	48	50	50	48,5	44,5	48	49,5	46,5
Min. outdoor air temperature at indoor air temp. 20°C DB (*)	-5	-3	12	14,5	14,5	-5	10	13,5	13,5	13
Min. outdoor air temperature at Max indoor air temp. 23°C DB / 47%HR	12	14	13	15	29	13	11	14	14	13
Max. entering air temperature at outdoor air Temp. 38°C DB	35	40	39	41	55	31	29	32	48	48
Max. entering indoor air temperature at Max outdoor air temp. 48°C DB / 40%HR	28	31	31	31	31	27	28	30	31	31
Min. entering indoor air temperature at outdoor air temp. 35°C DB	14									
Min. entering indoor air temperature at Max outdoor air temp. 48°C DB / 40%HR	14	14	15	16	19	14	14	14	16	17
Heating mode operating limits given for steady state running condition with noted temperature condition										
Min. outdoor air temperature at indoor air temp. 20°C DB	-15									
Min. outdoor air temperature at Min indoor air temp. 5°C DB/ 59%HR	14	3	5	2	-2	15	16	10	2	0
Min. entering indoor air temperature	5	5	5	5	5	5	9,5	7	5	5
Max. entering indoor air temperature	25									
Max. outdoor air temperature at Max indoor air temp. 25°C DB / 59%HR	24	23	24	23	24	23	24	23	25	29
Min. outdoor air temperature at indoor air temp. 20°C DB / 100%fresh air / with electrical Std pre-heater	2,3	0	1	0	5	4	5	3	5	5
Min. outdoor air temperature at indoor air temp. 20°C DB / 100%fresh air / with electrical High pre-heater	-8	-10	-9	-8	2	-3,5	-2	-4	-6	-7

(*) below these values, option "Low ambient kit" is required

Fix Speed Compressors

	E022AH077F	E022AH087F	E022AH107F	E022AH140F	E024AH078F	E024AH088F	E024AH108F	E024AH126F	E024AH141F	E027AH160F	E027AH180F
Envelopes in °C											
Cooling mode operating limits given for steady state running condition with noted temperature condition											
Max. outdoor air temperature at indoor air temp. 27°C DB / 19°C WB	48										
Max. outdoor air temperature at Min indoor air temp.DB / 47%HR	48										
Max outdoor air temperature with unloading	52	53	49,5	51,5	51,5	52,5	49	49	51	49,5	49,5
Min. outdoor air temperature at indoor air temp. 20°C DB (*)	12,5	6,5	13,5	16	12	6	12,5	12,5	15	7	7
Min. outdoor air temperature at Max indoor air temp. 23°C DB / 47%HR	14	7	14	29	13	8	13	13	9	7	20
Max. entering air temperature at outdoor air Temp. 38°C DB	35	34	46,5	37,5	29,5	28,5	44	44	36,5	41	36,5
Max. entering indoor air temperature at Max outdoor air temp. 48°C DB / 40%HR	31	28	31	31	30	28	31	31	31	31	31
Min. entering indoor air temperature at outdoor air temp. 35°C DB	14										
Min. entering indoor air temperature at Max outdoor air temp. 48°C DB / 40%HR	14	14	16	20	18	19	14	14	17	17	19
Heating mode operating limits given for steady state running condition with noted temperature condition											
Min. outdoor air temperature at indoor air temp. 20°C DB	-15										
Min. outdoor air temperature at Min indoor air temp. 5°C DB/ 59%HR		-3	5	-15		2	12	8	-15	-15	-15
Min. entering indoor air temperature	13	5	5	5	14	5	7	5	5	5	5
Max. entering indoor air temperature	25										
Max. outdoor air temperature at Max indoor air temp. 25°C DB / 59%HR	29	23	29	23	26	24	30	29	23	24	24
Min. outdoor air temperature at indoor air temp. 20°C DB / 100%fresh air / with electrical Std pre-heater	6	5	1	5	8	0	3	2	5	5	5
Min. outdoor air temperature at indoor air temp. 20°C DB / 100%fresh air / with electrical High pre-heater	-4	5	-8	4	-2	-9	-5	-6	5	5	5

Option Variable Speed Compressors

	E016AH105F	E019AH124F	E027AH160F								
Envelopes in °C											
Cooling mode operating limits given for steady state running condition with noted temperature condition											
Max. outdoor air temperature at indoor air temp. 27°C DB / 19°C WB	45	45	45								
Max. outdoor air temperature at Min indoor air temp.DB / 47%HR	45	45	45								
Max outdoor air temperature with unloading	47	47	47								
Min. outdoor air temperature at indoor air temp. 20°C DB (*)	5	5	6								
Min. outdoor air temperature at Max indoor air temp. 23°C DB / 47%HR	20	20	20								
Max. entering air temperature at outdoor air Temp. 38°C DB	42	37,5	43								
Max. entering indoor air temperature at Max outdoor air temp. 48°C DB / 40%HR	31	31	31								
Min. entering indoor air temperature at outdoor air temp. 35°C DB	14	14	14								
Min. entering indoor air temperature at Max outdoor air temp. 48°C DB / 40%HR	19	19	19								
Heating mode operating limits given for steady state running condition with noted temperature condition											
Min. outdoor air temperature at indoor air temp. 20°C DB	-15	-15	-15								
Min. outdoor air temperature at Min indoor air temp. 5°C DB/ 59%HR	-15	-15	-15								
Min. entering indoor air temperature	5	5	5								
Max. entering indoor air temperature	25	25	25								
Max. outdoor air temperature at Max indoor air temp. 25°C DB / 59%HR	24	24	24								
Min. outdoor air temperature at indoor air temp. 20°C DB / 100%fresh air / with electrical Std pre-heater	5	5	5								
Min. outdoor air temperature at indoor air temp. 20°C DB / 100%fresh air / with electrical High pre-heater	5	5	5								

Casing Condensation Risk

Depending of the ambient outdoor conditions and the supply air performance of the unit, some condensation on the outside skin of the unit casing may appear. This outside condensation doesn't affect the good operation of the unit, but can only affect the visual aspect of the unit.

Find below graph with condensation risk limits depending on:

- Outside Relative Humidity (% HR)
- Delta temperature (K) between Outdoor dew point temperature and Dry supply air temperature

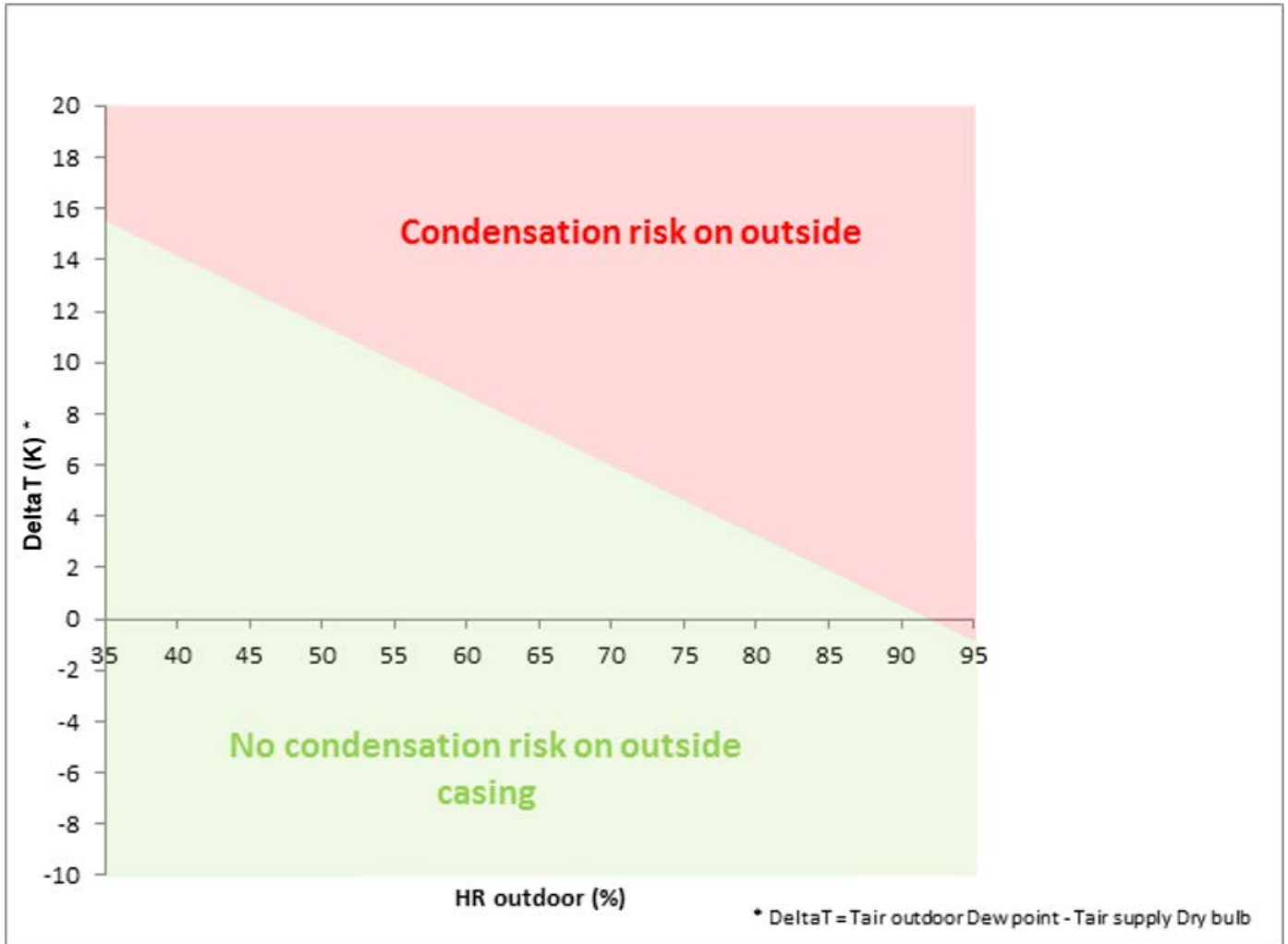

WARNING: commissioning must only be carried out by trained refrigeration engineers whom qualification certificates are compliant with the local regulation

Before turning on the power

WARNING: ensure that the power supply includes 3 phases with no neutral

Ensure that the power supply between the building and the unit meets local authority standards and that the cable specification satisfies the start-up and operating conditions displayed on the rating plate.

Wire connection tightness checks

WARNING: check the wire connection tightness before powering up the unit. Some connections may have loosen during transport

Check the following wire connections for tightness:

- Main switch connections
- Mains wires linked to the contactors and circuit breakers
- Cables in the 24V control supply circuit
- All others connections of the unit

OIL CHARGE

All units are delivered with a complete oil charge, and there is no need to add any oil before start up or afterwards. Overcharging with oil can cause serious problems on an installation, particularly for the compressors.

Refrigerant	Compressor type	Oil Type
R410A	Scroll	The oil type depends on compressor model that depends on the unit size. Use only oil approved and recommended by Lennox

Powering the unit

Power up the unit by closing the isolator switch.

The fans and compressors direction of rotation is checked during the end of line test. They should therefore all turn in either the right or wrong direction.

WARNING: a compressor rotating in the wrong direction will fail shortly.

If one of the components rotates in the wrong direction, disconnect the power supply at the machine's isolator switch and reverse two of the component's phases on the terminal within the electrical panel.

While starting the unit, fill in the check list sheet of this manual to be sure that the unit correctly installed and ready to operate.

- Check the current values per phase on each fan motor.
- Check the current values per phase on each compressor motor.
- Check suction and discharge pressures and compressor suction temperature.
- Check chilled liquid entering and leaving temperatures if water cooled unit.
- Check outdoor air temperature and indoor temperature.
- Check if DAD is ON.

These verifications should be made as quickly as possible with a stable cooling load, i.e. the cooling load of the installation should be the same as the capacity developed by the unit. Measurements taken without heeding this condition will result in unusable and probably wrong values.

These verifications can only be made once the proper operation of all safety devices and unit controls has been established.

Check if the customer's air ducts are open to be sure the unit is not running with ducts closed. In addition it is needed to check if the airflow and available static pressure are in accordance with the unit.

CLIMATIC™ configuration

Settings

- 1. Supply Air-flow adjustment (depending on customer requirements)**
 - a. 3333 = nominal air flow / pressure
 - b. 3334 = reduced air flow / pressure
 - c. 3332 = Manual/Automatic
 - d. 3331 = Nominal/DeadZone/PartLoad/Pressure

- 2. Exhaust Air-flow adjustment (optional)**
 - a. 3864 = nominal air flow
 - b. 3865 = reduced air flow

- 3. Scheduling (depending on customer requirements)**
 - a. Zones & Modes (Night/Day/Day I/ DayII)
 - b. Setpoints per mode

- 4. Regulation temperature probe selection**
 - a. Select the regulation probe (DC, Return, Customer, etc.) in the Room Temp. Config screen

- 5. Regulation humidity sensor selection (optional)**
 - a. Select the regulation sensor (Remote, Customer) in the Room Hum. Config screen

- 6. Outside temperature probe selection**
 - a. Select the outdoor temp probe (Unit, Customer) in the Outside Temp. Config screen

- 7. Outside humidity sensor selection (optional)**
 - a. Select the outdoor hum sensor (Unit, Customer) in the Outside Hum. Config screen

- 8. Air quality sensor selection (optional)**
 - a. Select the air quality CO2 sensor (Remote, Customer) in the CO2 Config screen

- 9. Remote display configuration**
 - a. 3151 = DC simple / DC full / DM

- 10. Minimum fresh air**
 - a. 3121 = minimum opening %

Check:

1. Air-flow Vs Damper

- a. Test B.Nom100% :
 - i. adjust the blower speed % (3333) to get the required air-flow
 - ii. adjust the exhaust speed % (3864) to get the required air-flow
- b. Test B.Nom0%:
 - i. adjust the damper compensation (3335) to maintain the required air-flow even with damper fully closed
 - ii. adjust the damper compensation (3366) to maintain the required air-flow even with damper fully closed

2. Filter safety thresholds

- a. Test B.Nom100% and Test B.Nom0% : read filter ΔP (3442) and adjust the bigger measure multiplied by 2.5 at threshold 3345

3. Frigorific circuit tests

- a. Cooling mode
 - i. Test C---Cool: (if variable speed compressor option, set speed value)
 - 1. Check circuit pressures and temperatures
 - 2. Check electrical consumptions
- b. Heating mode
 - i. Test C---Heat: (if variable speed compressor option, set speed value)
 - 1. Check circuit pressures and temperatures
 - 2. Check electrical consumptions

4. Unit option tests

- a. Electrical Auxiliary heaters (Test H1-1 Full)
 - i. Check supply temperature
 - ii. Check electrical consumption
- b. Hot Water Auxiliary heaters (Test H1-1 Full)
 - i. Check supply temperature ii. Check valve opening
- c. Gas burner heaters (Test H1-1 Full)
 - i. Refer to gas burner chapter
- d. Electrical Fresh-air pre-heaters (Test H2-1 Full)
 - i. Check supply temperature
 - ii. Check electrical consumption
- e. Hot water eRecovery heaters (Test H2-1 Full)
 - i. Check supply temperature ii. Check valve opening
- f. TRMO
 - i. Test C3---Cool:
 - 1. Check circuit pressures and temperatures
 - 2. Check electrical consumptions
 - ii. Test C3---Heat:
 - 1. Check circuit pressures and temperatures
 - 2. Check electrical consumptions
- g. HRMO (Rotary Wheel)
 - i. Check wheel motor rotation

WARNING! During the settings, wait until the economizer is fully closed or opened, since it takes 1-2 minutes to switch.

5. Advanced regulation optimization

- a. Compressor ΔT
 - i. Cooling.
 - 1. Test C1c1 Cool: read | Mix-Supply| temp and adjust compressor stage ΔT at menu 3434
 - ii. Heating.
 - 1. Test C1c1 Heat: read | Mix-Supply| temp and adjust compressor stage ΔT at menu 3444
- b. Auxiliary Heaters ΔT (Gas burner or electrical)
 - i. Heating.
 - 1. Test H1-1: read | Mix-Supply| temp and adjust heaters stage ΔT at menu 3734
- c. Staging sequence (compressor/electrical/water/burners)
 - i. Aux Heaters Priority 3731= Never/ Always /OutTemp
 - ii. Pre Heaters Priority 3736= First/Last
- d. Dynamic setpoint
 - i. 3225= ΔT between customer set point and outdoor temperature
- e. Fine temperature control
 - i. Smooth 3231= No/ DeadZone/Comfort

6. Leak Detection

- a. Cooling
 - i. Test C1--Cool: read Subcooling and adjust 3437
 - ii. Test C2--Cool: read Subcooling and adjust 3438
- b. Heating
 - i. Test C1--Heat: read Subcooling and adjust 3447
 - ii. Test C2--Heat: read Subcooling and adjust 3448

Once all the settings have been adjusted, the list of parameters must be downloaded (Wizard tool), stored and signed by the customer.

Installing

The fresh/exhaust air hoods have to be opened and secured during commissioning. The 3 parts of the air hood have to be assembled thanks to M5 screws delivered in the spare part box. Check the proper position of the black seal on the top of the hood cover.

Wind direction

The prevailing wind has to be taken into account while choosing the machine position on the building roof. It's highly recommended to avoid putting the fresh air hood in the prevailing wind direction to avoid water ingress risks. If this is not possible please contact us to require specific water droplet strainer in the hood section.

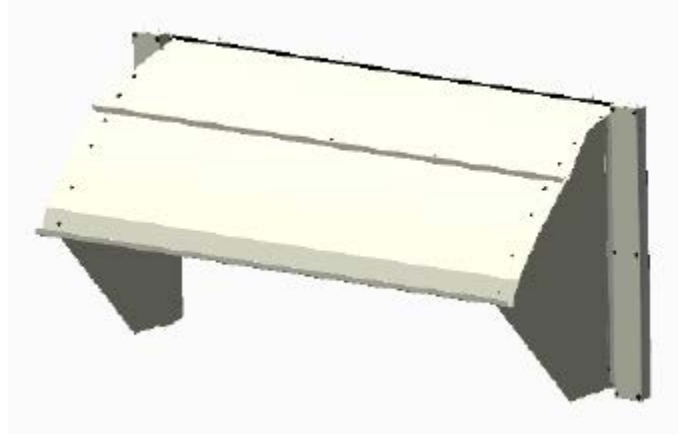

WARNING: the fresh air hood cover can hurt your head if you don't pay attention while turning around the unit.

Fit the hygrometric sensor. Only after opening of the fresh air hood, put in front of the air flow the hygrometric sensor.

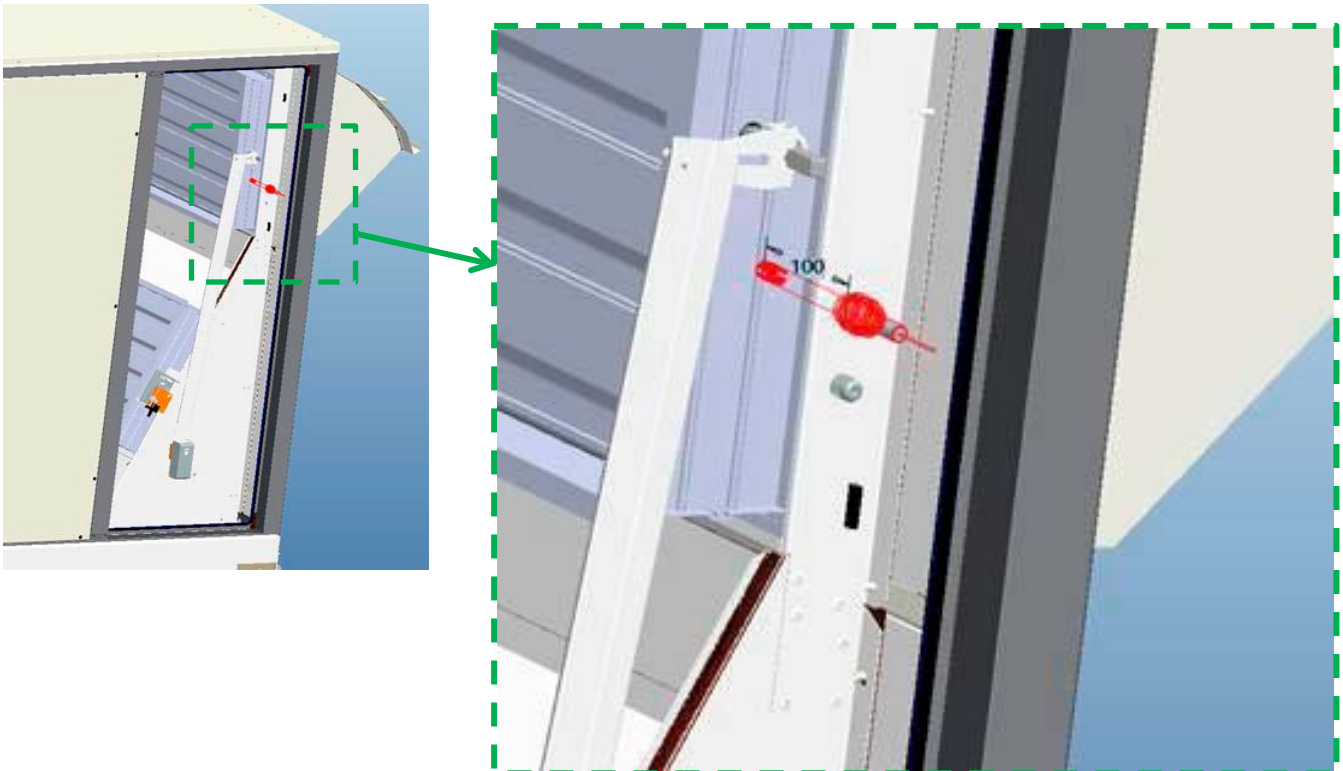

Filters replacement – Air treatment box

After opening the filter access panel, remove the filter stop.

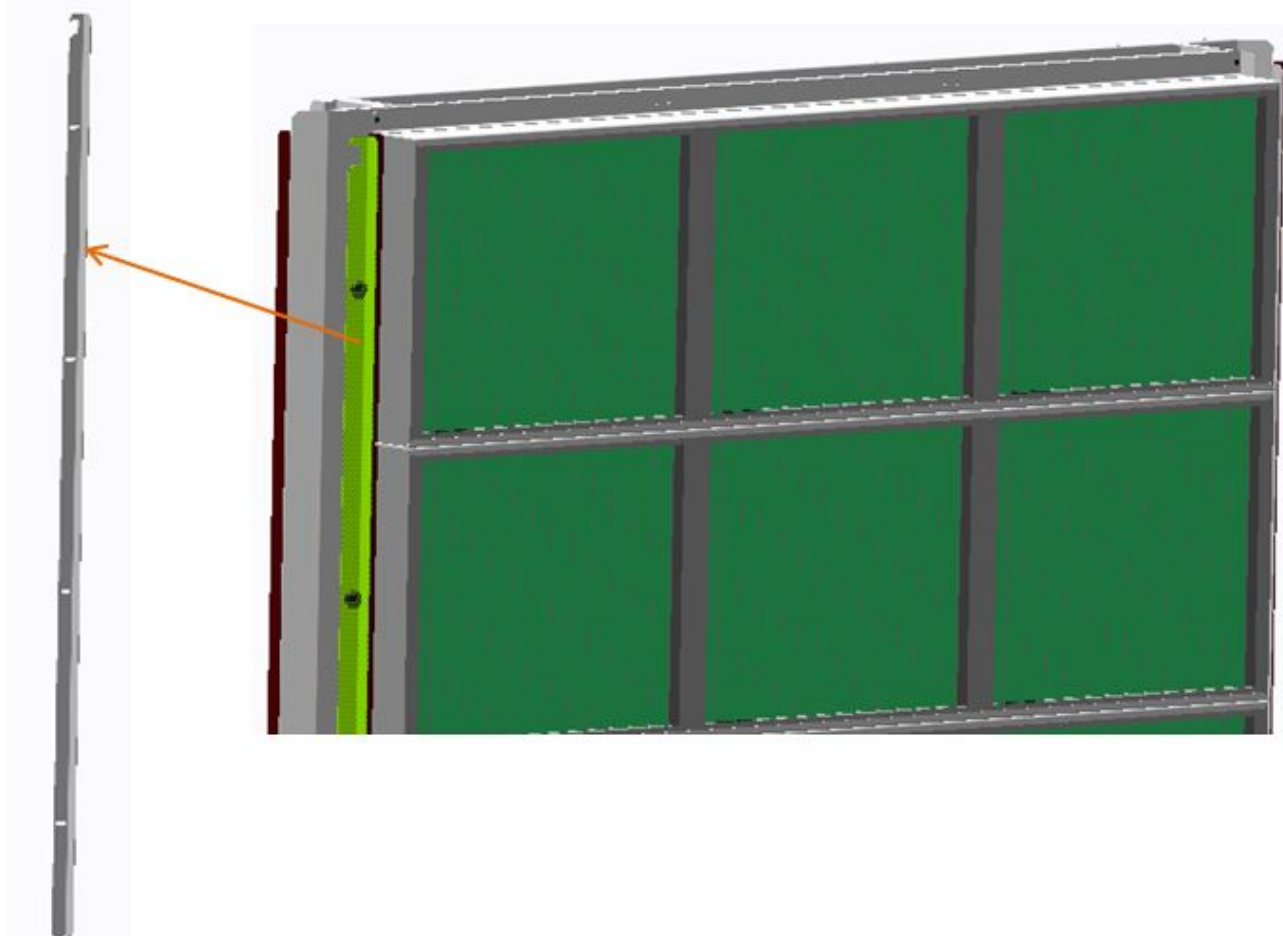

Use this stop to slide the dirty filters out one by one into the rail.

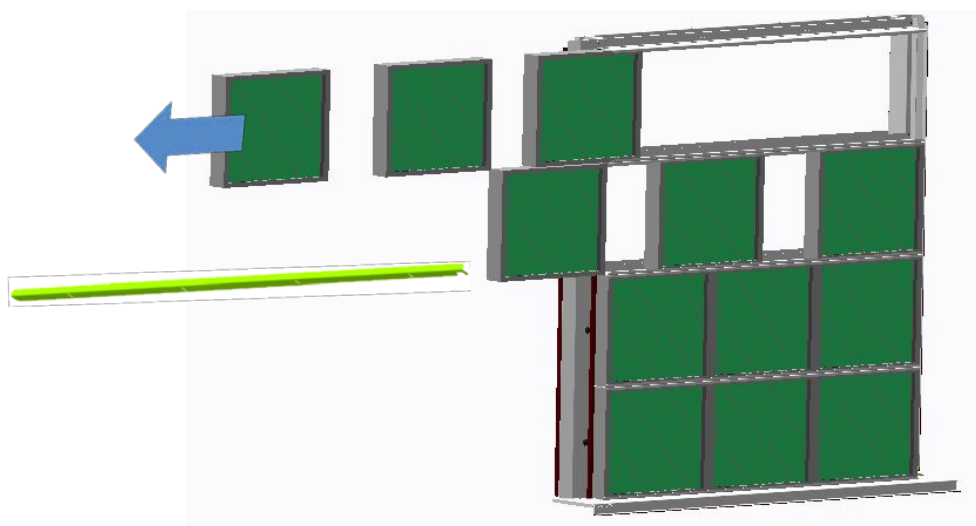

Replace the dirty filters by clean ones (respect the airflow direction).

Warning: it's mandatory to use only filters supplied by Lennox. Only these filters are adapted to the unit, and are designed to ensure the requested filtration quality and the correct air pressure drop. Otherwise you may affect the filtration quality and/or the pressure drop, with a risk of clogging the unit and/or risk on performance of the unit.

This operation must be repeated for each filter level: G4 / F7 / F9. There is one stop for each filter level.

Filters replacement – options

Some options have also their filters that need to be replaced. For the options, use the stop of the air treatment box to slide out the filters.

Rotary Wheel:

Vertical return

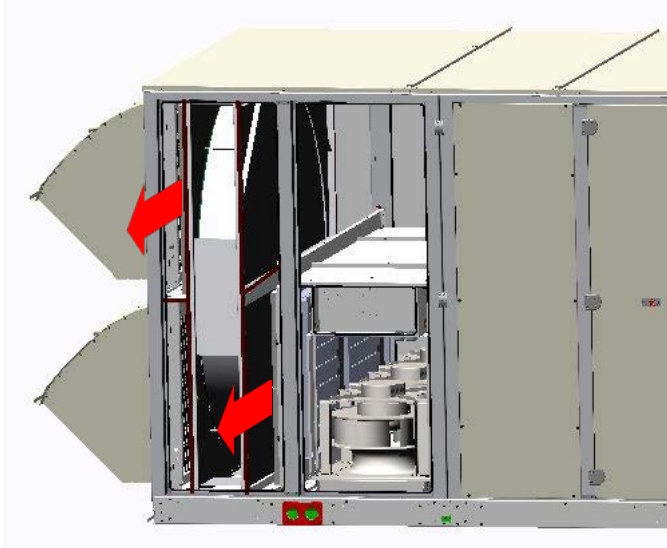

Horizontal return

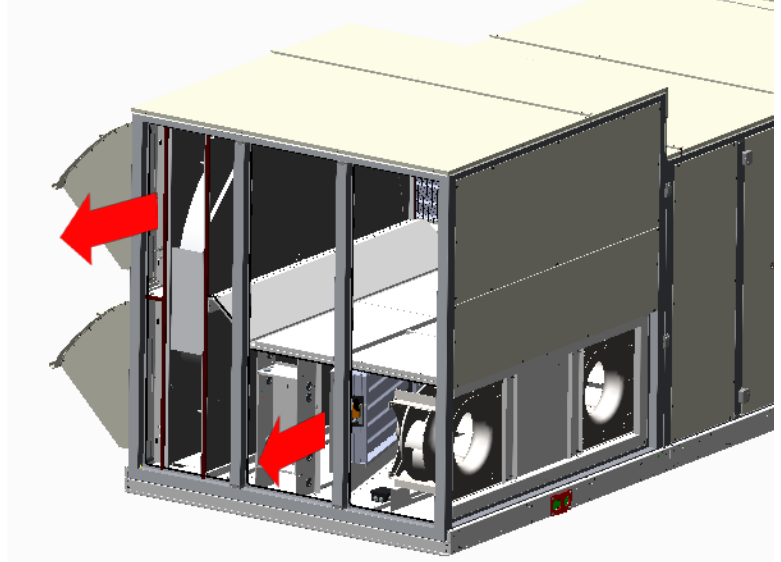

Thermodynamic heat recovery module (TRMO):

Vertical return

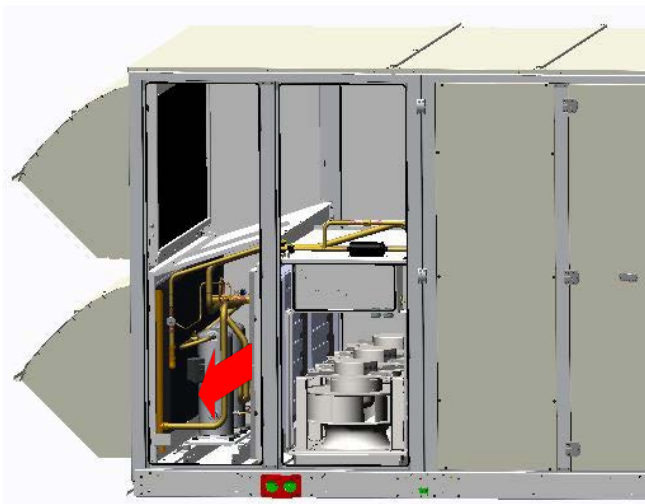

Horizontal return

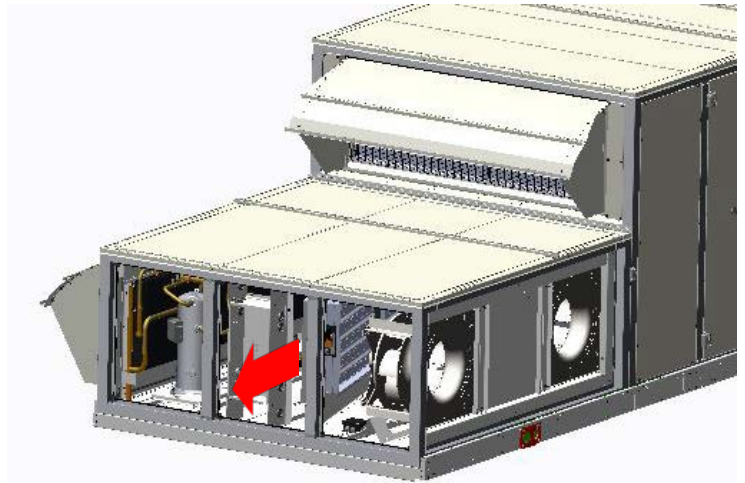

Warning: it's mandatory to use only filters supplied by Lennox. Only these filters are adapted to the unit, and are designed to ensure the requested filtration quality and the correct air pressure drop. Otherwise you may affect the filtration quality and/or the pressure drop, with a risk of clogging the unit and/or risk on performance of the unit.

Generic refrigerant sketch

Depending on the unit size, the number of compressors can change (Single or Tandem), the number of filter dryer can change (1 or 2 in parallel), the liquid receiver can be present or not. Some connection valve (Schrader type) are available to load/unload the circuit.

UNITS

- E014AH055FM1M
- E014AH065FM1M
- E019AH066FM1M
- E014AH075FM1M
- E019AH076FM1M
- E016AH085FM1M
- E019AH086FM1M
- E016AH105FM1M
- E019AH106FM1M
- E019AH124FM1M
- E022AH077FM1M
- E024AH078FM1M
- E022AH087FM1M
- E024AH088FM1M
- E022AH107FM1M
- E024AH108FM1M

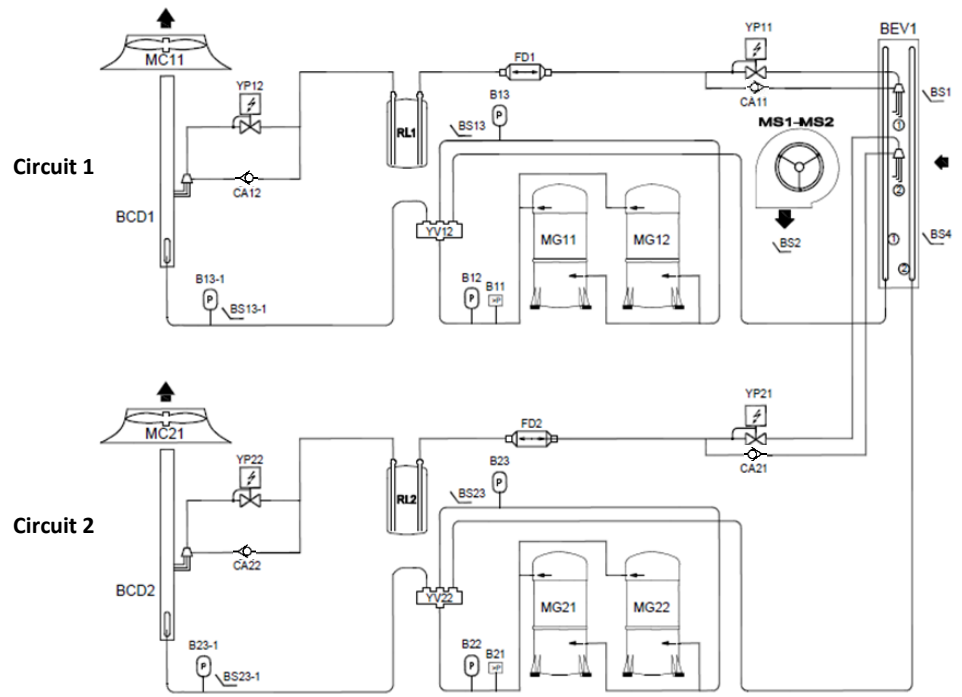

UNITS

- E024AH126FM1M
- E022AH140FM1M
- E024AH141FM1M
- E027AH160FM1M
- E027AH180FM1M

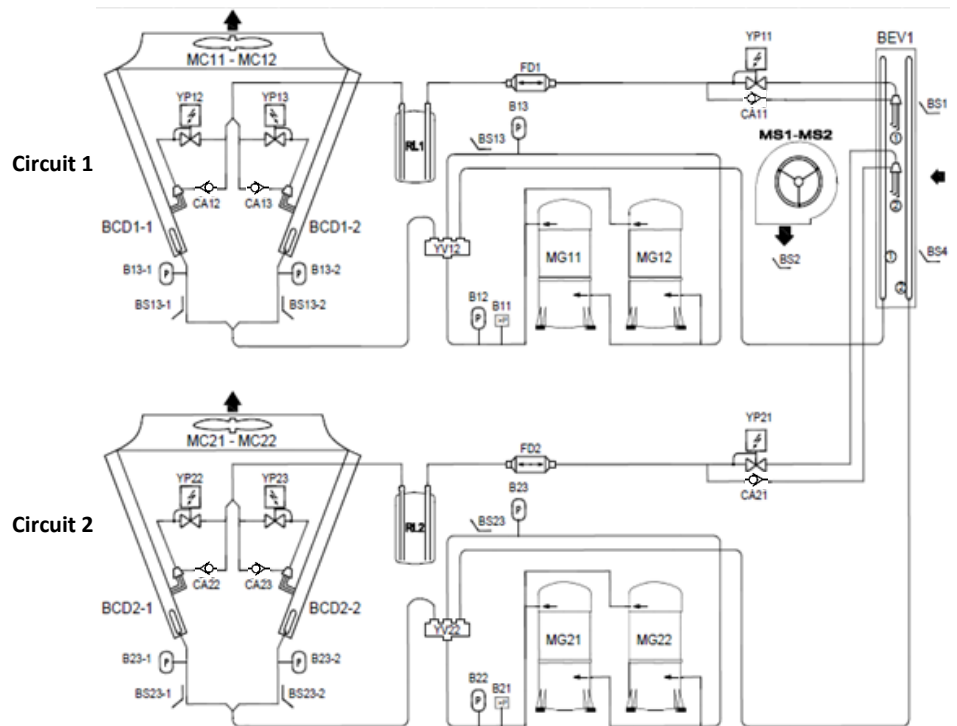

BEV-	Indoor coil
BS-	Temperature sensor
YP-	Expansion valve
CAT-	Check valve
FD-	Filter dryer
RL-	Liquid receiver
BCD-	Outdoor coil
B-	Low/High pressure switch
YV-	Cycle reversal valve
MG-	Compressor

Preheating of the crankcase heaters

It's important to avoid to start the compressors without preheating of the crankcase heaters.

WARNING: In case of extended shutdown of the unit (> 6 hours), it is mandatory to power on the unit 8 hours minimum before to start the compressors equipped with crankcase heaters.

Vacuum

On each refrigerant circuit there are connection valves on the low pressure side and high pressure side.

WARNING: In case of vacuum, never connect the vacuum pump only for Low Pressure connection valve. In this case there is a risk of not vacuuming the complete circuit. In order to vacuum the circuit, it is necessary to connect the vacuum pump on both low pressure and high pressure simultaneously

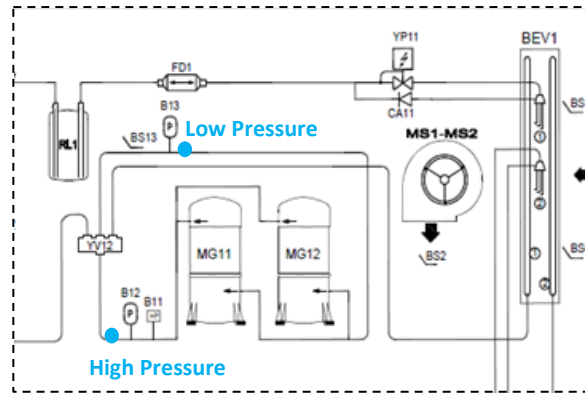

EEV adjustments

EEV allows the control of superheat.

E2V welding instructions

Electronic expansion valves are sensitive to dust – strainers must be used in case of replacing.

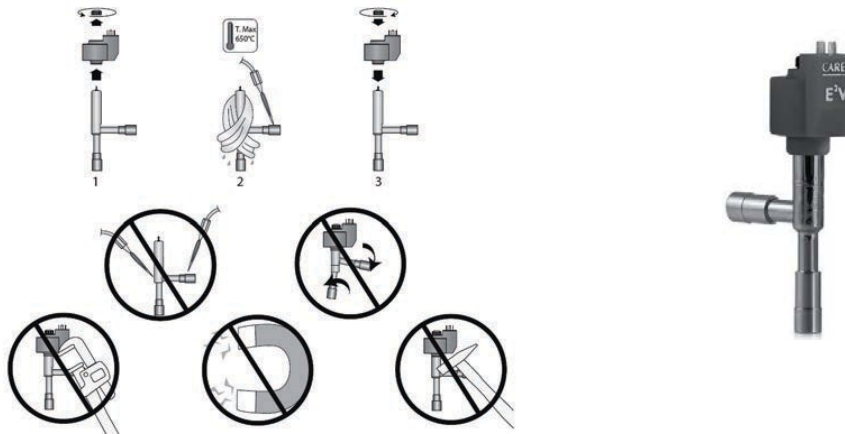

E3V welding instructions

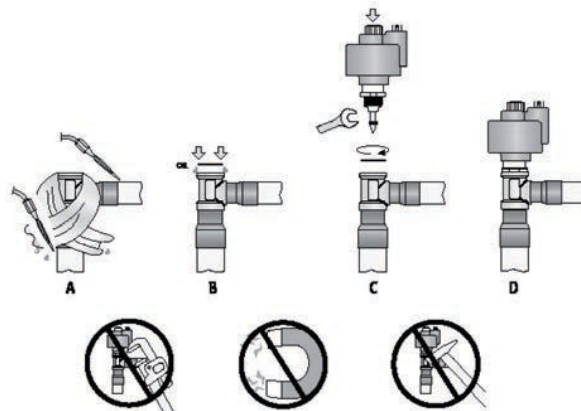

Hot (and cold) water coils

The hot (and cold) water coil is fitted with a three way proportional valve. Two spanners must be used to tighten the connections. One spanner must maintain the valve body when connecting the pipe. Failure to do so may damage the pipes joints and invalidates the warranty.

Filling up and starting the system

- Adjust the control for Heating by reducing the simulated ambient temperature down to 10°C
- Check that the red indicators located under the valve actuator are moving correctly with the signal.
- Fill the hydraulic system and bleed the coil using the air vents. Check incoming hot water flow rate.
- Check the various connections for possible leaks

Maximum working pressure :

8 Bars

Maximum working temperature :

110 °C

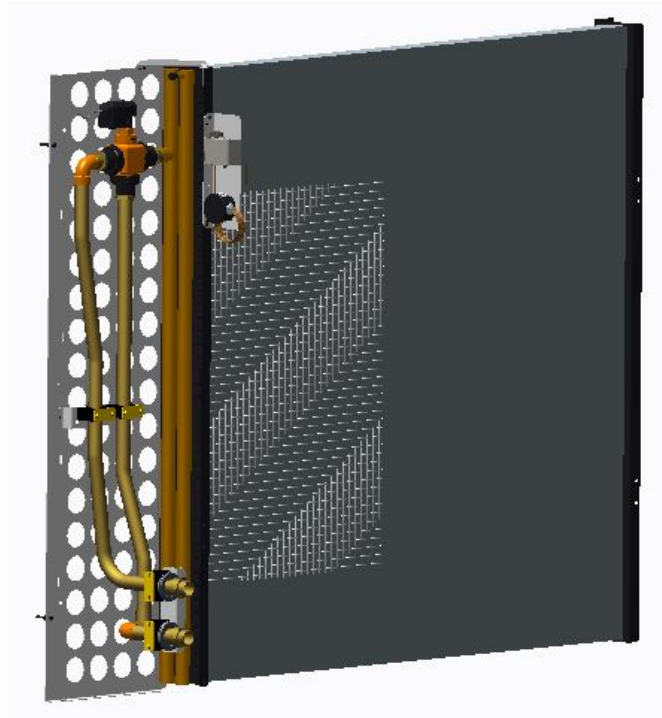

Freeze protection

Check the hydraulic system contains glycol for protection against freezing. Glycol is the only effective protection against freezing. The antifreeze must protect the unit against freezing under winter conditions.

Warning: glycol based fluids may produce corrosive agents when mixed with air.

Drain the installation

You must ensure that the manual or automatic air vents have been installed on all high points in the system. In order to drain the system, check that all the drain valves have been installed on all low points of the system.

Water coils frozen due to low ambient conditions are not covered by the warranty.

Electrolytic corrosion

Attention is drawn to the corrosion problems resulting from electrolytic reaction created by unbalanced earth connections. Any coil damaged by electrolytic corrosion is not covered by the warranty.

Cold water coil specificity

In case of cold water coil, it's necessary to insulate the water pipes of the water loop inside the unit to prevent any condensing risk.

eRecovery

eRecovery water coil is delivered with 3 ways valve included
It is placed just before the standard coil of the unit.

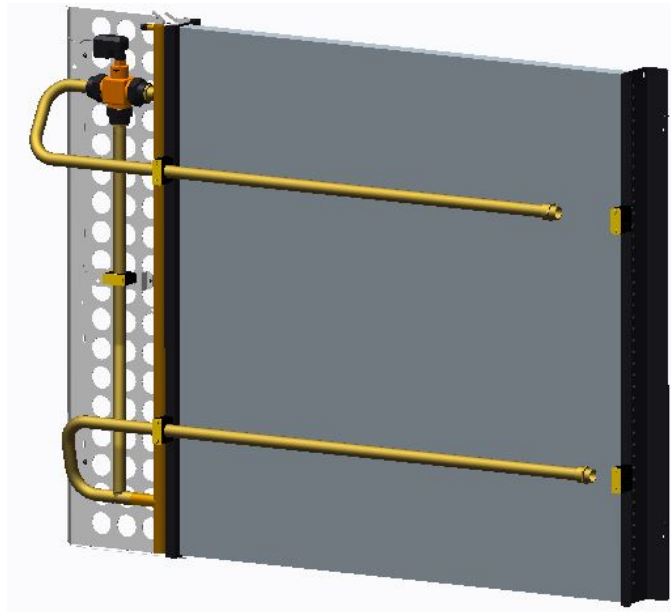

The freeze protection is made via fresh damper safeties nevertheless a full freezing protection has to be done using glycol.

Water pipes connection

Water pipes of the hot (and cold) water coil & eRecovery water coil are placed inside the unit. Connection (Inlet/outlet) with the water loop must be realised inside the unit. Some adjustable sealing parts are forecasted and mounted on the side of the unit (right hand side airflow direction) so that the water loop pipes can go through the panels. See picture below:

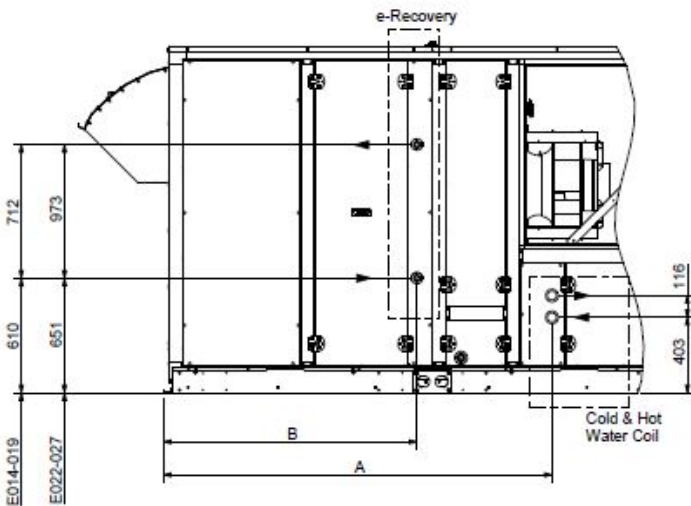

Cold & Hot Water Coil

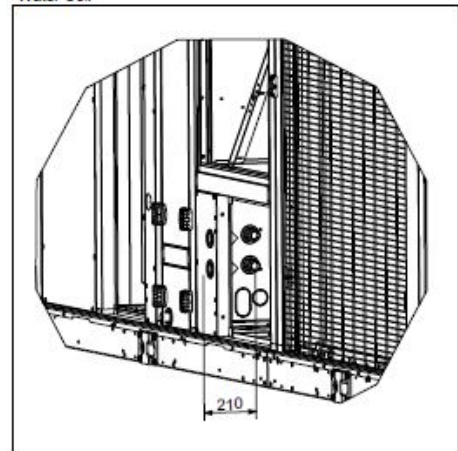

e-Recovery

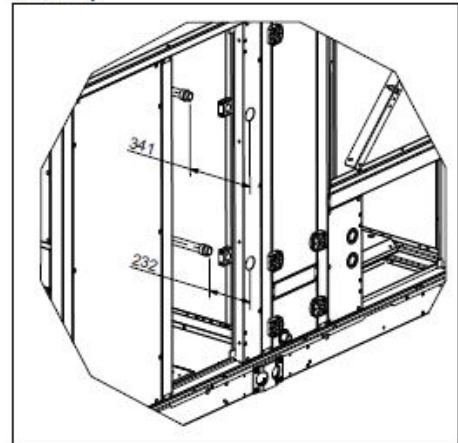

	Standard	Extraction Vertical	Rotary Wheel Vertical Thermodynamic Heat Recovery Vertical	Extraction Horizontal Rotary Wheel Horizontal Thermodynamic Heat Recovery Horizontal
A	2070	3031	3619	4247
B	1350	2311	2899	3527

	E014 - E019	E022 - E027
Water Coil Small - Threaded male	DN25 - 1"	DN32 - 1"1/4
Water Coil High - Threaded male	DN32 - 1"1/4	DN40 - 1"1/2
e-Recovery - Threaded male	DN32 - 1"1/4	DN40 - 1"1/2

All dimensions in millimeters

WARNING: electrical heater is connected to main power – risk of electrical shock – switch off the unit prior to open this section

The electrical heaters are placed after the coil.

It is protected as standard against overheating via a high temperature overload protection.

There are three sizes available for each size of unit:

S: Standard heat

M: Medium heat

H: High heat

Unit	Description	Type of modulation	Capacity	Current
E014- E019	Standard	1 stage	36 kW	52 A
	Medium	Triac	90 kW	129,9 A
	High	Triac	108 kW	155,9 A

Unit	Description	Type of modulation	Capacity	Current
E22- E27	Standard	1 stage	54 kW	77,9 A
	Medium	Triac	108 kW	155,9 A
	High	Triac	144 kW	207,8 A



Electrical preheater

WARNING: electrical pre-heater is connected to main power – risk of electrical Shock – switch off the unit prior to open this section

The electrical preheaters are placed before the coil.

Pre-heater is running only with high fresh air rate under low outdoor ambient temperature (see setpoint in control section).

It is protected as standard, against overheat via a high temperature overload protection set at 98°C.

There are three sizes available for each size of unit:

S: Standard heat

M: Medium heat

H: High heat

Unit	Description	Type of modulation	Capacity	Current
E014- E019	Standard	Triac	36 kW	52 A
	Medium	Triac	90 kW	129,9 A
	High	Triac	108 kW	155,9 A

Unit	Description	Type of modulation	Capacity	Current
E22- E27	Standard	Triac	54 kW	77,9 A
	Medium	Triac	108 kW	155,9 A
	High	Triac	144 kW	207,8 A



Preliminary checks before start-up

Note:

Any work on the gas system must be carried out by qualified personnel.

This unit must be installed in accordance with local safety codes and regulations and can only be used in planned installation conditions for outdoor.

Please read carefully the manufacturer's instructions before starting a unit.

Before commissioning a unit with gas burner, it is mandatory to ensure that the gas distribution system (type of gas, available pressure...) is compatible with the adjustment and settings of the unit.

The gas module safety chain must be checked by a professional before start-up of the product.

Check access and clearance around the unit

- Make sure someone can move freely around the unit;
- A minimum one-meter clearance must be left in front of the burnt gas exhaust flue;
- Combustion air inlet and burnt gas exhaust(s) must not be obstructed in any way;
- The installation of the gas pipes should permit to open all panels of the units.

Supply network pipe sizing

Male threaded connection for gas burner: 3/4" or 1"1/2 depending on gas burner size (refer to unit drawing)

Check that the gas supply line can provide the burners with the pressure and the gas flow rate necessary to provide the heating nominal output.



WARNING: Do not forget to connect the condensate drain. The condensates must absolutely be drained at least 5 meters from the unit into an appropriate place/evacuation. The condensates are corrosive and could damage the unit (or other parts of the installation) if they are not drained properly.

Safety instructions

FUEL:

Before starting up the heater, make sure that:



- The gas mains supply data is compatible with the data stated on the nameplate;
- The combustion air intake ducts (when fitted) and the fume exhaust pipes are those specified by the manufacturer;
- The combustion air is supplied in such a way to avoid even partial obstructions of the intake grille (caused by leaves etc.);
- The fuel intake internal and external seal is checked during the testing stage, as required by applicable standards;
- The heater is supplied with the same type of fuel it has been designed for;
- The system is correctly sized for such flow rate and is fitted with all safety and monitoring devices required by applicable standards;
- The inside of the gas pipes and air distribution ducts for ducted heaters has been thoroughly cleaned;
- The fuel flow rate is suitable for the power required by the heater;
- The fuel supply pressure is between the range specified on the nameplate.

GAS LEAKS

If you smell gas:

- Do not operate electrical switches, telephones or any other object or device that could produce sparks;
- Immediately open doors and windows to create an air flow to vent the gas out of the room;
- Close the gas valves;
- Call for qualified staff.

Product range

Unit	Description	Model		Capacity
E14-E19	Standard	PCH 80		16-82 Kw
	High	PCH 105		18-100 Kw
E22-E27	Standard	PCH 105		
	High	PCH 210	18-200 Kw	

MODEL		PCH080		PCH105		PCH210	
		min	max	min	max	min	max
Chimney loss -burner ON (hi)	%	0,3	2,4		2,8		2,8
Chimney loss -burner OFF (hi)	%	<0,1		<0,1		<0,1	
Max.Condensation produced (1)	l/h	3,3		2,7		5,4	
Carbon monoxide CO (0% diO2) (2)	ppm	2	0	0	2	0	2
Nitrogen oxides-Nox -(0% diO2) (3)	mg/kWh	34		45		45	
Available flue pressure	Pa	120		120		120	
Power supply	V	230Vac -50Hz					
Power absorbed	W	40	123	20	130	40	260
Size air inlet/exhaust pipes	mm	80/80					
Maximum applicable pressure	Pa	1200					

(1) Max. Condensation produced value obtained by test at 30% Nominal load (Qn)

(2) Value reference with gas cat. H (G20)

(3) Value (statistical medium calculation) EN1020 reference gas cat. H (G20)

General introduction of the PCH

- Premix burner (venturi, gas fan, pilot group, head) gas valve
- Electronic controls with display
- Combustion chamber in stainless steel AISI 430 (AISI 441 in the next future)
- Exchanger bundle in stainless steel AISI 441
- Safety thermostat (and additional probe)

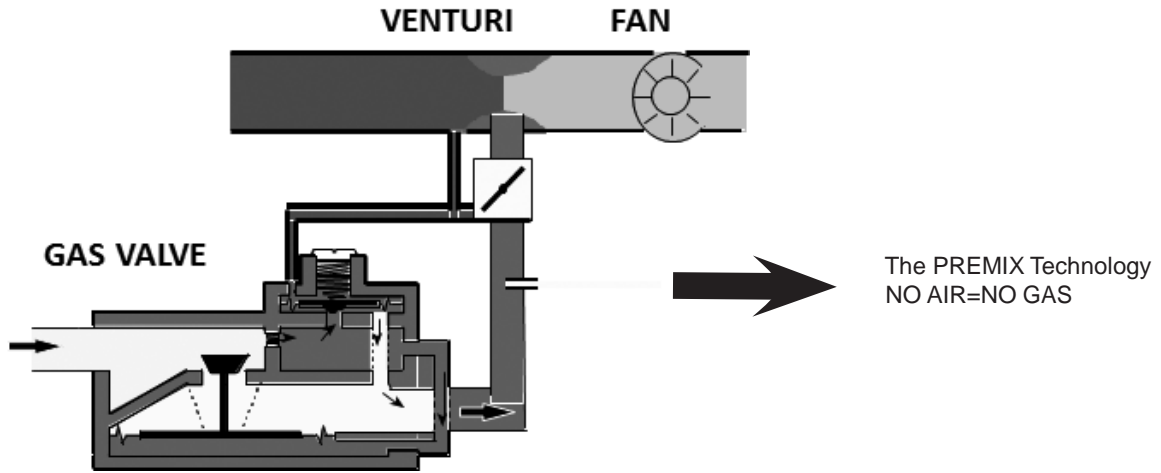

PCH working cycle

- Heat is required
- Burner fan starts to pre-wash combustion chamber EV1 and EVP gas valves open to gas feed pilot burner
- Start up electrode gives ignition sparks on pilot burner
- EV2 main gas valve opens to gas feed main burner
- Combustion starts thanks to pilot flame ignition
- The electronic boards close EVP and stops the pilot

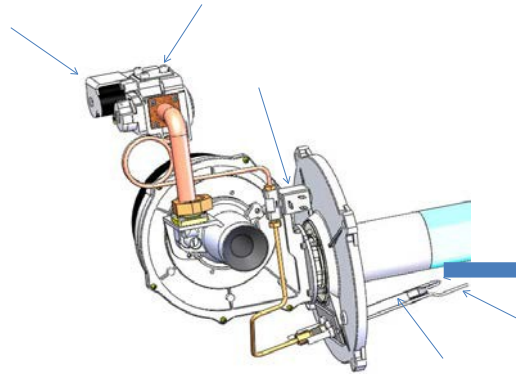
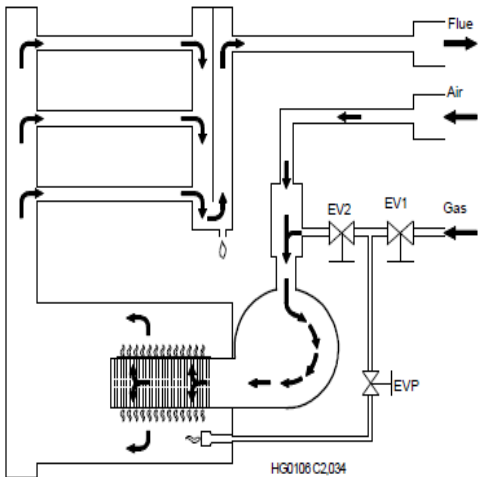

Air fans

ON delay ≤ 60" after the burner ON

OFF delay ≥ 180" after the burner OFF

Possible safety devices of the fans must be connected in series with the burner (ID1/IDC on terminal CN08)

STB and temperature probe

Safety Thermostat STB: it stops the burner at 100°C (manual reset required by Gas Directive)

NTC temperature probe: it forces the burner to modulate (factory set of ST1 = 45°C) or to stop (f.s. of TH1=60) before the STB, automatic reset as soon as the air temperature decreases. Fault F51 recorded.

Connections

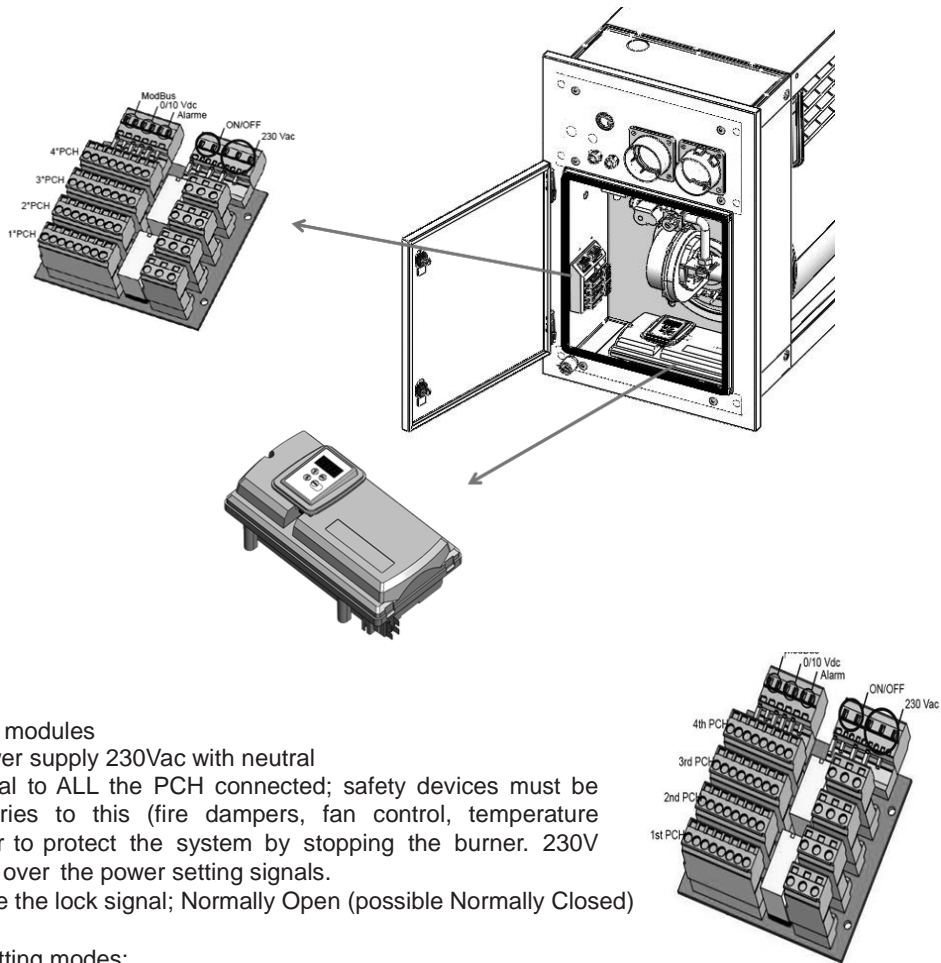

- 1 or 2 gas Supply modules
- Single-phase power supply 230Vac with neutral
- ON/OFF: ok signal to ALL the PCH connected; safety devices must be connected in series to this (fire dampers, fan control, temperature alarms...) in order to protect the system by stopping the burner. 230V supplied. Priority over the power setting signals.
- ALARM: to remote the lock signal; Normally Open (possible Normally Closed)

3 possible power setting modes:

- NTC1 temperature probe (parameter d0=2). Only with 1 PCH; "delivery fixed point" operation; the burner is switched on and off through the ON/OFF.
- **0-10Vdc (d0=5, default factory setting)**
- Modbus (d0=7): modulation board provided with a serial RS485 which may be used to control the burner start-up, the modulation, the alarms, the reset.

Installation

Gas connection

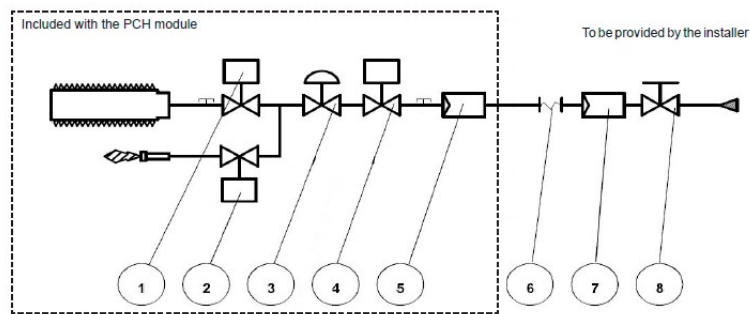

- 1 Main burner gas solenoid valve
- 2 Pilot burner gas solenoid valve
- 3 Pressure stabiliser
- 4 Safety gas solenoid valve
- 5 Gas filter (small section)
- 6 Anti-vibration joint
- 7 Gas filter (large section)
- 8 Gas valve

It is strictly prohibited to supply gas to the circuit with pressure higher than 60mbar. Such pressures could cause the valve to break. If pressure are higher than 60mbar, a pressure reducer must be installed at least 10 m away and no pressure stabiliser must be fitted between the pressure reducer and the heater, but leaving the gas filter.

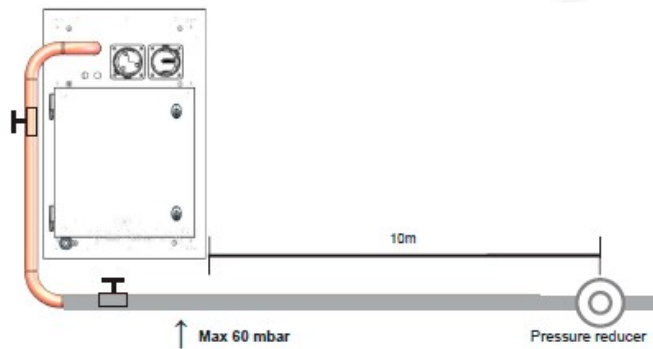

Condensate drain

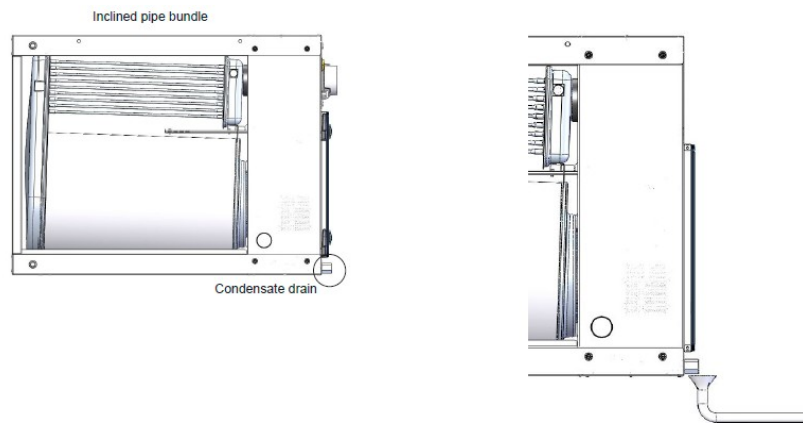

WARNING: Do not forget to connect the condensate drain (No need to add a siphon). The condensates must absolutely be drained at least 5 meters from the unit into an appropriate place/evacuation. The condensates are corrosive and could damage the unit (or other parts of the installation) if they are not drained properly.

Supply sensor with PCH vertical: After installation of duct, place the sensor in “running” position by pushing the metallic support.

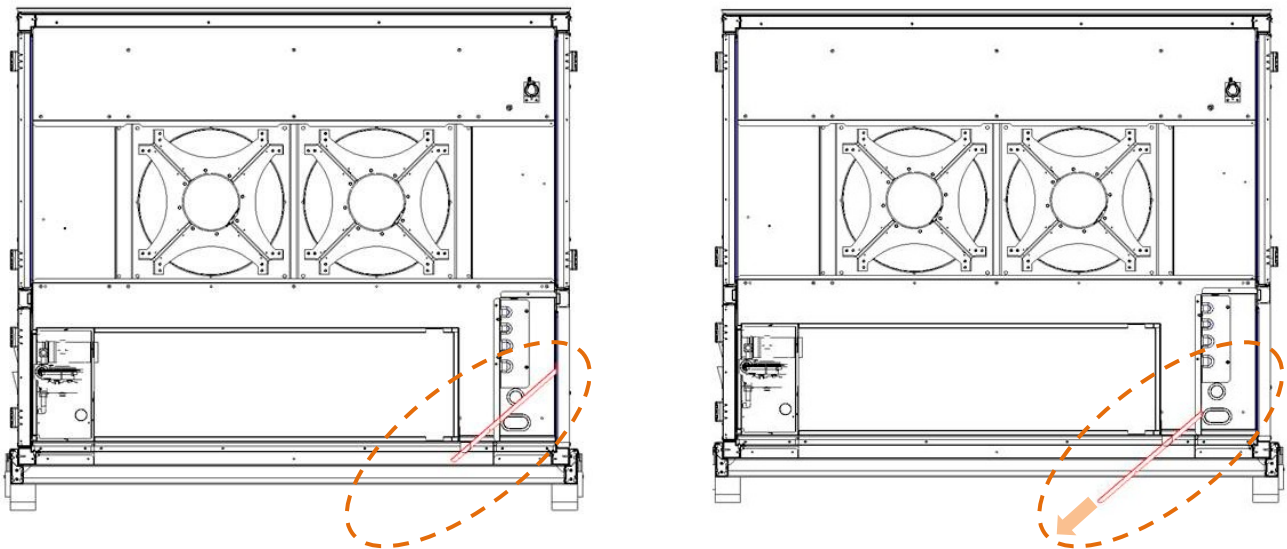

Starting for the first time

The PCH heater unit is supplied with settings entered and tested for the gas specified on the nameplate. Before turning on the PCH unit, check the following:

- Make sure the gas in the mains corresponds to that for which the PCH is controlled;
- Check, with the pressure intake "IN" on the gas valve, that the pressure entering the valve corresponds to that required for the type of gas being used;
- Check that electrical connections indicated in electrical diagrams attached to the unit;
- Check that efficient earthing connections have been completed, carried out as specified by current safety regulations;
- Provide power to the heater with the general switch on the machine and insert the power plug in the inside of the compartment;

To turn on the heater, follow the instructions below:

- Check that RDY appears on the display. If OFF appears, use the command, under FUN, to turn the machine to ON;
- Check the LCD display to verify that the Tin value is greater than the Von value. When ON appears on the LCD display, the heater starts the ignition cycle.

NOTE: Frequently, when turned on for the first time, the pilot burner cannot ignite because there is air in the gas hose. This will block the equipment.

You will need to unblock the equipment and repeat the operation until it ignites.

Analysis of combustion

Check that the heater is at maximum or minimum power.

Use the LCD display to reach the REG menu, then use the Hi and Lo commands to force operation at maximum or minimum capacity.

- Check again that the input pressure in the valve corresponds to that required; adjust if necessary.
- Perform the combustion analysis to verify that the level of CO₂ corresponds to figures in the tables.
- If the measured value is different, turn the adjustment screw on the venturi. Unscrewing the screw will raise the level of CO₂, screwing it down will lower the level.
- Place the heater on minimum capacity, and verify that the level of CO₂ corresponds to figures in the tables. If the measured value is different, repeat the procedure.

TYPE OF GAS G20													
TYPE OF EQUIPMENT		PCH020		PCH034		PCH045		PCH065		PCH080		PCH105	
Power		min	max	min	max	min	max	min	max	min	max	min	max
CATEGORY		according to the country of destination - see reference table											
GAS SUPPLY PRESSURE	[mbar]	20 [min 17-max 25] *											
Ø PILOT NOZZLE	[mm]	0.7											
GAS CONSUMPTION (15°C-1013mbar)	m ³ /h	0.51	2.01	0.80	3.69	0.90	4.44	1.31	6.88	1.74	8.68	1.90	10.58
CARBON DIOXIDE -CO ₂ CONTENT	[%]	8.8	9.1	8.7	9.1	8.7	9.1	8.7	9.1	8.7	9.1	8.5	9.1
FUMES TEMPERATURE	[°C]	39	113	31	94	30	94	31	86	26.5	70	28	80
FUME MASS FLOW RATE (MAX.)	[kg/h]	31		57		72		107		135		165	
Ø GAS DIAPHRAGM	[mm]	5.8		7.4		7.5		11		12.2		15.8	
Ø AIR DIAPHRAGM	[mm]	Not required		Not required		Not required		Not required		Not required		Not required	

* For Hungary, the air supply pressure is 25 mbar

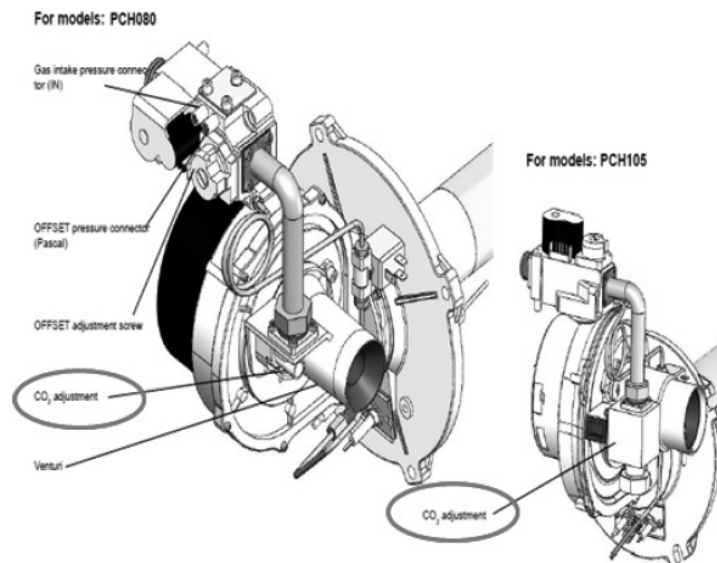

Interface panel

Status:

rdy the unit is waiting for the ON control and/or the heat demand from the room thermostat (ready - no flame)

ON burner flame or ignition

OFF unit off by a command from the display panel, any heat demands will be ignored

Fxx Fault detected.

Air The EST function in the FUN menu was selected by mistake.

Axx Address of the PCH unit when $\neq \emptyset$ (alternating with the operation in progress)

CPU or ... flashing: communication problems CPU-SMART/LCD panel



Menus:

3 levels

↑ and ↓ to scroll the menus, ENTER to select,

ESC back to the "unit status" after about 10 minutes

change in the parameter (press ENTER for at least 3") signalled by a flash of the display

First level menus

Unit status

- FUN to select the function ON, OFF or EST
- REG to force the burner to min or max
- I/O to read values measured by the sensors
- TIN to read the value of the 0/10Vdc signal
- Pra not used;
- ABI to enter the psw to access 2nd and 3rd level

Second level menus

Set to read and set parameters for the 0/10V

Check 0/10 Vdc - D0=5			
H51		1	Active only with D0=5 (0/10V) 0=only modulation; 1=modulation and ON/OFF
H52	V	0.5	Voltage of OFF, burner shut down if H51=1: 0=10 1Module = 0.5; 2Modules = 1.5; 3Modules = 2.5; 4Modules = 3.5.
H53	V	0.5	Delta Voltage for ignition burner ON 1Module = 0.5; 2Modules = 1.0; 3Modules = 1.5; 4Modules = 1.5.
H54	sec	10	Duration of lower input: 0=255
H55	sec	10	Duration of upper input: 0=255

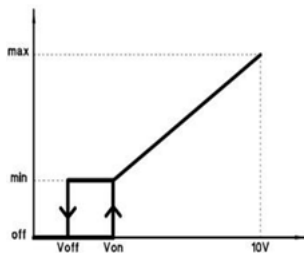

Modulation and ON/OFF

H51=1(factory set)

Voff = H52 = 0,5V (factory set)

Von = H52 + H53 = Voff + H53 = 0,5+0,5 = 1V

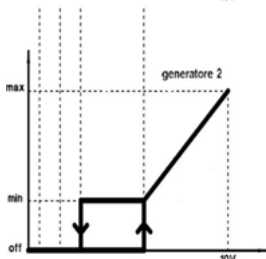
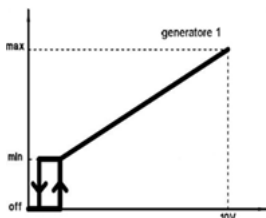

	PCH1	PCH2
H52	0,5	1,5
H53	0,5	1,5
V_{on}	1,0V	3V
V_{off}	0,5V	1,5V

See below the relation between signal from Climatic and PCH

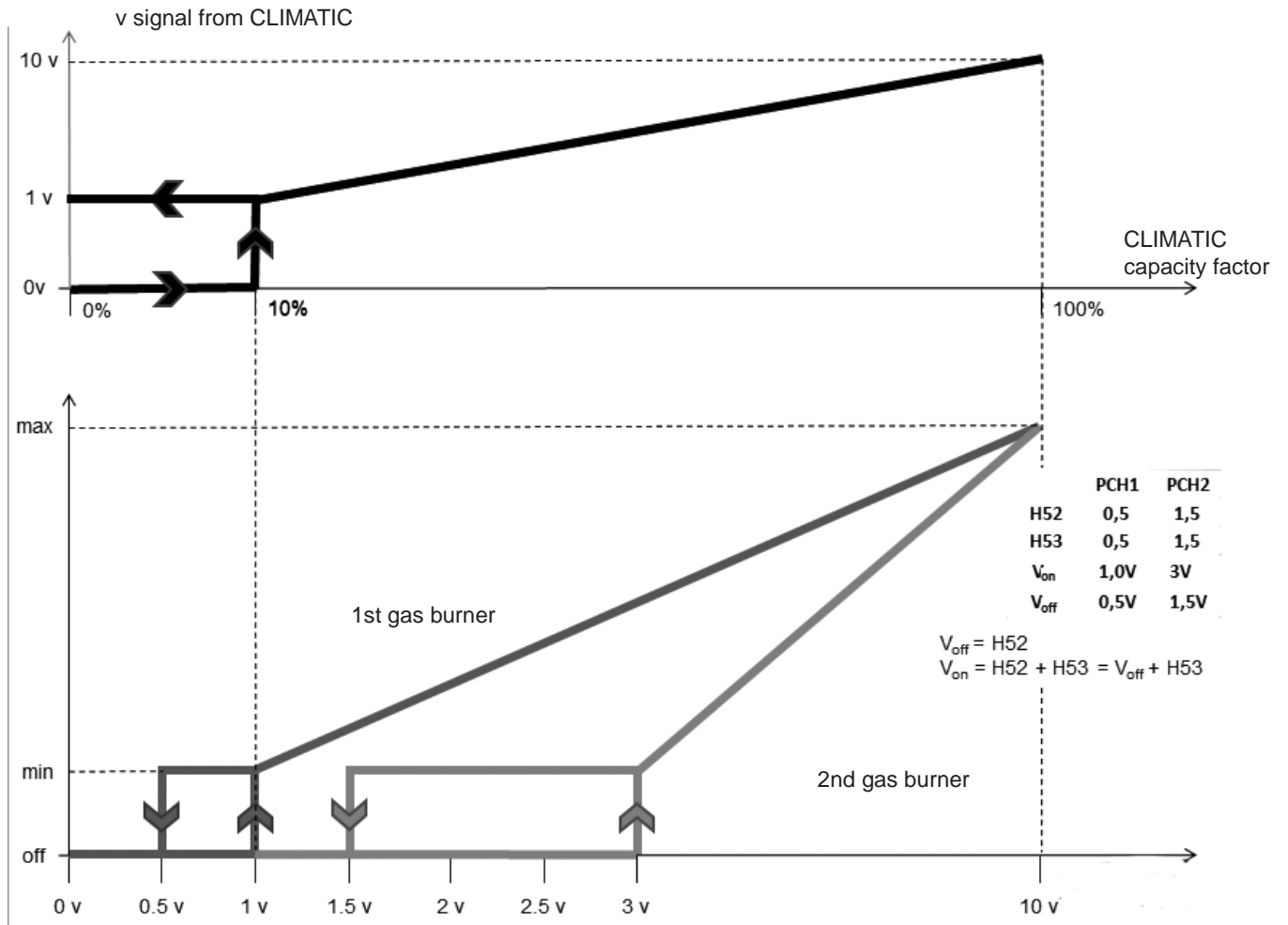

Third level menus

- PAR to read and set parameters for the burner and for the configuration of operation
- Flt to display the fault history

List of faults

FAULT	DESCRIPTION	CAUSE	REMEDY
Blocks caused by Flame - Dependent on the TER equipment			
F10	Failure to ignite flame after 4 attempts performed by the equipment.	<ul style="list-style-type: none"> Phase and neutral reversed. Earth wire not connected. Phase-phase connection without neutral. Start-up electrode failed or badly positioned Detection electrode failed or badly positioned Detection electrode that moves or disperses to the earthing system when hot. Low CO₂ value 	Manual reset
F11	Ill-timed flame		
F12	Failure of ignition; not visible. The count, displayed in the historical list, indicates whether the heater has had problems with ignition.		
F13	The TER equipment does not accept the reset command from CPU-SMART	TER has finished its 5 reset attempts in the period of 15 minutes.	Wait 15 minutes or use reset button on equipment
F14	Lack of communication between TER equipment and CPU for more than 60 seconds	TER equipment or CPU-SMART PCB broken	Auto-reset
F15	The CPU-SMART PCB sent the ignition signal to the equipment. After 300 seconds, the equipment has not yet lit the flame.	safety thermostat blocking start up	Check contact closing
		TER equipment broken	Manual reset
F16	Generic equipment block	TER equipment broken	Manual reset
F17	Internal malfunction of TER equipment that does not accept reset command from CPU-SMART	TER equipment broken	Manual reset of equipment
Blocks caused by temperature (safety blocks)			
F20	Intervention of safety thermostat STB	<ul style="list-style-type: none"> Excess air temperature due to lack of air circulation Safety thermostat broken or not connected 	Manual reset
F21	Input ID1 open caused by: NOT USED - Jumped	Jump missing ID1 - IDC1	Manual reset of CPU-SMART
Block FAN - burner ventilator			
F30	Fan speed too low in start up phase - VAG	Burner fan broken. FAN electrical cables broken or not connected	Manual reset
F31	Fan speed too high in start up phase - VAG		
F32	Fan speed, during operation, out of minimum and maximum set parameters - VAG		Manual reset, auto-reset after 5 minutes
NTC probes broken or missing			
F41	Probe NTC1 error, air intake temperature	Absence of signal from probe or broken probe	Auto-reset
Over-temperature			
F51	The temperature of the air intake probe NTC1>TH1	<ul style="list-style-type: none"> The minimum heat power of the PCH heater module is over-dimensioned compared to the heat power required by the environment. Check the TH1 parameter - air intake set point. 	Auto-reset if NTC1< TH1-15
Check ModBus communication			
F60	Communication error between CPU-SMART PCB and ModBus network, SmartControl or SMART.NET	<ul style="list-style-type: none"> ModBus network is disconnected. The address of the PCB is wrong and/or not configured in the ModBus network. 	Auto-reset
Lack of voltage			
F75	Lack of voltage during operation cycle (excluding stand-by); the fault is not visible on remote control but only counted.	Lack of electricity during operation	Auto-reset
Internal malfunction of CPU-SMART PCB			
F00	Internal malfunction of CPU-SMART PCB	Perform a manual reset of the PCB; replace the CPU-SMART if the problem persists.	Manual reset

To reset an alarm trip, press simultaneously both arrow keys during a few second

Maintenance operations

To keep the machine in efficient condition and guarantee a long lifetime of the heater, it is advisable to run some inspections every year, before turning it on for the season:

1. check the status of the start-up electrodes, detection electrodes and pilot flame;
2. check the status of fume exhaust and air intake ducts and terminals;
3. check the status of the venturi;
4. check and clean the exchanger and burner are clean;
5. check and clean the water trap
6. check the intake pressure at the gas valve;
7. check the function of the flame monitoring equipment;
8. check the safety thermostat(s);
9. check the ionization current.

NOTE: Operations at points 1, 2, 3, 4 and 5 must be performed after disconnecting the heater from the electrical mains and closed the gas intake. Operations at point 6, 7, 8 and 9 must be done with the heater on.

1) Inspection of electrodes

Dismantle the complete pilot flame and use a jet of compressed air to clean the mesh and nozzle. Check the integrity of the ceramic and use sandpaper to remove any oxidation on the metal parts of the electrodes. Check the correct position of the electrodes (see drawing below). It is important that the detection electrode is at a tangent to the head of the pilot and not inside it. The start-up electrode must discharge onto the mesh of the pilot burner.

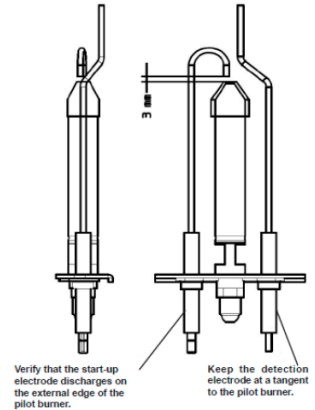

2) Inspection of fume exhaust and air intake ducts

Visually inspect where possible or examine with specific tools to learn the status of the ducts. Remove dust that forms on the air intake terminal.

3) Inspection and cleaning of the venturi

Remove any dirt at the mouth of the venturi with a brush, and be careful to not let it fall inside the piece.

4) Inspection and cleaning of the exchanger and burner

Perfect combustion in PCH heaters prevents dirt, which is normally caused by bad combustion. It is advisable, therefore, to not clean the exchanger and burner unless there are exceptional circumstances.

An accumulation of dirt inside the exchanger could be revealed by a sizeable variation in the gas capacity that is not caused by improper functioning of the gas valve.

Should it become necessary to clean the burner and/or exchanger, all of the gaskets mounted between the burner and the exchanger must be replaced.

5) Inspection and cleaning of the water trap

Clean the trap every year, and check the connections. Make sure there are no traces of metallic residue. If metallic residue has formed, increase the number of inspections.

6) Inspection of intake gas pressure

Verify that the intake pressure at the valve corresponds to the value required for the type of gas that you are using. This verification must be done with the heater on at the maximum heat capacity.

7) Inspection of flame monitoring equipment

With the heater operating, close the gas tap and verify that the machine blocks, signalled on the LCD display on the CPU PCB on the machine with code F10. Reopen the gas tap, reset the block and wait for the heater to start back up.

8) Inspection of safety thermostat(s) and air pressure gauges

This procedure must be done with the heater on and the burner lit. Open the thermostat series with an insulated tool [230 V], remove the fast-on from the safety thermostat, and wait for the F20 block signal to appear on the LCD display on the CPU PCB on the machine. Reclose the thermostat series, then reset the block.

9) Verify the ionization current.

This procedure can be done directly from the LCD display by entering into the I/O menu. The IOn parameter indicates the value of the ionization current, and the reading is as follows:

- 100, indicates that the value is more than 2 microAmperes, which is plenty for the equipment to function.
- From 0 to 100, indicates a value from 0 to 2 microAmperes; for example, 35 corresponds to 0.7 microAmperes, which is the minimum threshold detectable for the flame monitoring equipment.

The value of the ionisation current must not be below 2 micro-Amperes. Lower values indicate: the detection electrode in a bad position, a rusted electrode or one about to stop functioning

Refrigeration

Fault	Possible cause and symptoms	Solution
LP problems and LP cut outs	Refrigerant charge too low	Measure the superheat and sub-cooling: Good if $5^{\circ}\text{C} < \text{sc} < 10^{\circ}\text{C}$ and $5^{\circ}\text{C} < \text{sh} < 10^{\circ}\text{C}$ Bad if $\text{sc} > 10^{\circ}\text{C}$ and sh too low Check superheat adjustment and charge unit (a leak check must be carried out)
	In heat pump mode the temperature difference between t outdoor and t evap. (dew) is too high 5K < delta t < 10K excellent 10K < delta t < 15K acceptable 15K < delta t < 25K too high	If too high check the coils are clean or check coil internal pressure drop between the liquid line and the suction line Good if < 3bar Too high if > 3bar (coil blocked)
	Refrigeration circuit blocked in distribution	Stop the fan and create icing of the coil. Check all circuits freeze evenly across the whole surface of the coil If some parts of the coil do not freeze this could indicate a problem with the distribution
	Liquid line drier blocked. High temperature difference between inlet and outlet of the drier	Change filter drier
	Contaminant in the expansion valve	Attempt to free the valve adjusting element by freezing the valve and then heating the thermostatic element. Replace the valve if necessary
	Expansion valve not adjusted properly	Adjust the expansion valve
	Ice plug in the expansion valve.	Heat the main body of the valve. If the LP increases and then decreases gradually, empty the circuit and replace the drier.
	Incorrect insulation of the thermostatic bulb of the expansion valve	Superheat too low: adjust superheat Move the thermostatic element along the pipe Insulate the thermostatic element of the valve
	Low pressure switch cut out point too high	Check the cut out pressure of the low pressure switch: it must be $0,7 \pm 0,2 \text{ bar}$ and must closes at $2,24 \pm 0,2 \text{ bar}$
LP cut out due to not enough defrost on heat pumps	Adjust the CLIMATIC™ settings to extend the defrost cycles or shorten the time between defrosts	
HP problems and HP cut outs	Incorrect airflow rates	Heat pump mode: check the filter before the indoor coil measure and estimate the airflow rate increase the speed of the fan Cooling mode: check the condenser fan (amps)
	Moisture or contaminants in the system	Summer operation Several hours after the unit has stopped, check the correspondence between the measured pressure and the outdoor temperature

TRMO

Fault	Possible causes and symptoms	Solution
Low LP and LP cut out	Alarm 317: main frigorific issue	Lack of charge, obstructed components
	Alarm 327: too low LP	Freezing: wait that coil is defrosted by exhaust air. Too low airflow rate on evaporating side (too low speed rate / fouled filter or coil).
HP problem and HP cut out	Incorrect airflow rates	Check fan (exhaust or supply) function of the mode (Amps) and also filter.
	Refrigerant charge too high	Check the refrigerant charge load according to the refrigerant load table.

Electrical heater

Fault	Possible cause and symptoms	Solution
High temperature trip out on electric heater	Low airflow rate	Measure and estimate the airflow and pressure and compare with the specification from customer.
	Incorrect position of the klixon	Check that the klixon, is positioned in the airflow, relocate klixon if necessary Check that there is no heat transfer from the klixon support.

Water leaks

Fault	Possible cause and symptoms	Solution
Water found in the ventilation section	Cooling mode: water carried away from the coil because of excessive airflow and speed on the coil.	Estimate the airflow rate and check the speed is lower than 2,8 m/s
	Low air pressure in the compartment due to a high airflow rate or a high pressure drop before the fan	Check filter Reduce airflow rate
	Check seals around the ventilation section.	Check the door seal Check for the presence of silicone seals in the corners of the door and at the bottom of the refrigeration section bulkhead.
Water ingress in the filter compartment	Water ingress through a leaking fresh air hood or when running 100% fresh air	Check the seals and flanges in the fresh air hood Reduce the airflow rate if necessary

CLIMATIC™ Displays

Fault	Possible cause and symptoms	Solution
Nothing is written on the screen but it's enlightened	Idem	Press on the three right-hand side's buttons at the same time during a few seconds then reconfigure display address setting at 32.
Nothing occurs on the unit or an option disappeared	Possible problem of units' configuration	Check the instructions from 3811 to 3833 and reconfigure options if necessary.
The message "no link" appears	Problem of addresses' recognition	Disconnect the DS from the unit and then reconnect it.
All the units are extinct	Problem main board plan addressing	Disconnect then re-plug; disconnect each unit from the others then change all the plan addresses

Terms and conditions

In the absence of any other written agreement, the guarantee shall only apply to design faults which occur within a 12 month period (warranty period).

The warranty period starts on the date of commissioning and at the latest six months after the delivery of the Rooftop.

Anti-corrosion warranty

10 year warranty terms and conditions for corrosion to the Rooftop casing:

LENNOX shall guarantee the casing of its Rooftop units manufactured against corrosion for 10 years commencing from the date of delivery of the material.

The warranty shall not apply in the following cases:

1. If the corrosion of the casing is caused by external damage to the protective layer such as scratches, projections, abrasion, impacts etc...
2. If the casing is not kept continually clean in the course of maintenance work or by a specialist company,
3. If the casing is not cleaned and maintained in accordance with regulations,
4. If the Rooftop units are installed on a site or in an environment which is known to be corrosive, unless a special protective coating has been applied by the owner for these applications, which has been recommended by a competent body not linked to the owner and after carrying out a study of the site.
5. Nevertheless the LENNOX coating is highly resistant to corrosion, the warranty will not be applied for rooftop installed at less than 1000 m away from the sea

Note: With the exception of the casing, the rest of the machine is covered by the warranty of our general terms of sale.

Lenguard warranty program

Warranty covers:

Parts only: Warranty applies to condenser coils, evaporator coils and hot water coils that would have been treated at the time of order. Warranty covers the repair or replacement of the defect part during the warranty period.

Warranty conditions:

- The above warranty is liable if the start-up and periodic maintenance agreement is contracted by a Lennox company or any company accredited by Lennox and if the coils are subject to a visual inspection every other week. In case of appearance of salt flower a hard treatment should be carried. If there is no need to run such treatment in-between, by default the coils should be cleaned with clear water and pH neutral soap every month. In addition, coils should be cleaned with low pressure steam every 6 months.
- All the periodic maintenance visits will be clearly recorded in the manual delivered with the equipment.
Warranty is void if:
 - The equipment has not been commissioned by Lennox or any company agreed by Lennox
 - There is no maintenance contract recorded from the date of start-up
 - Periodic maintenance visits as stated in our IOM recommendations are not recorded in the manual delivered with the unit, or a dedicated logbook.
 - Repairs under warranty have not been done by the nearest Lennox representative or any company agreed by Lennox
 - The equipment has not been installed, serviced and maintained in accordance with the installation, operation and maintenance instructions
 - The equipment is installed in a corrosive environment and adequate protection has not been taken (e.g. adequate coil coating for heavy marine environments)
 - The equipment is being used improperly, incorrectly, negligently or not in accordance with its nature and/or purpose.
 - Modifications have been made to the equipment without prior written permission by Lennox.
 - Settings and protections have been modified without prior written permission by Lennox
 - Non-original or other than the prescribed refrigerants or lubricants is used
 - The equipment is installed in a country different from the country stated on the invoice.

This warranty does not cover:

- Labour cost for Lennox or non-Lennox employees
- Regular maintenance and periodic services
- The replacement of casing parts (panels, screws, etc...)
- The replacement of consumable parts (filters, etc...)
- The replacement of parts other than fans, compressors, air or water heat exchangers.
- Replacements or repairs due to wear, abrasion or corrosion suffered by the equipment or damages resulting from transportation, negligence, failure to provide adequate supervision, lack of maintenance or improper storage conditions and non-respect of the Seller's recommendations.
- The cost of the time spent on preliminary work or on removal or reinstallation operations made necessary by the particular conditions of use and installation of the equipment (Ex: crane renting cost is out of the warranty coverage)
- Damage suffered by the hydraulic exchanger as a result of the refrigerated fluid freezing or of the use of an anti-freeze

liquid, which does not conform to the Seller's specifications.

- All failures resulting from a defect in parts or materials supplied by the Buyer.
- Tangible or intangible damages (lost profits, loss of products or consumables, or spoilage)
- Damage attributable to acts of God or force majeure occurring prior or subsequent to the commissioning of the equipment.

Do not confuse the warranty with maintenance

The warranty will only apply if a maintenance contract has been signed, starting from the date of commissioning, and if the maintenance contract has actually been performed.

The maintenance contract must be made with a specialist, competent company.

The sole effect of any repair, modification or replacement of an item during the warranty period must be to extend the material's warranty period.

Maintenance must be carried out in accordance with regulations.

If a spare part is supplied after the expiry of the warranty period, it shall be guaranteed for a period equal to the initial warranty period and will be subject to the same conditions.

We recommend for a contract four inspections per year (every three months), before the start of each season, in order to check the operation of the equipment in the various operating modes.

Lifetime of the equipment

The refrigerating system is designed for a lifetime of at least 10 years if the safety and maintenance instructions are strictly respected.

The lifetime of the equipment may be renewed if the periodic requalification certificate is validated by the expert (authorized body or DREAL)

Disposal of the equipment

Equipment shut-down and recuperation of oil and coolant must be carried out by qualified personnel conform to the recommendations of standard NF EN 378.

All elements in the refrigeration system such as refrigerant, oil, coolant, filters, dryers and insulating materials must be recuperated, re-used and/or disposed of in a correct manner (see NF EN 378 part 4). No materials may be discarded into the environment.

WARNING: for service and maintenance operations where refrigerant charge has to be removed, assure there is no refrigerant charge in the circuit.

Rooftops are generally placed on the roof but can also be installed in technical rooms. These units are very robust but a minimum regular maintenance is required. Some moving parts in the units can suffer from wear and tear and must be checked regularly (belts). Other parts can get clogged by dirt carried in the air (filters) and must be cleaned or replaced.

These units are designed to produce cooled or heated air through the use of a refrigeration vapour compression system, it is therefore imperative to monitor the refrigeration circuit operating pressures and check the pipe-work for leaks.

The table below, details a possible maintenance plan, including the operations to be carried out and the periodicity at which they must be accomplished. It is recommended to follow such a plan to keep a rooftop unit in good working order. Regular maintenance of your rooftop will extend its operating life and reduce operating faults

Symbols and Legend:

- Operation which can be carried out by on-site maintenance technicians.
- Operation which **must** be carried out by qualified refrigeration personnel, trained to operate on this type of equipment.

Note:

- Coil cleaning must be carried out by qualified personnel using appropriate methods that won't damage the fins or the tubes.
- It is recommended to keep a minimum stock of common replacement parts in order to be able to carry out regular maintenance operations (i.e. filters). You can contact your local LENNOX representative which can assist you in establishing a parts list for each type of equipment.
- The access ports to the refrigeration circuits **MUST** be leak checked every time gauges are connected to the service ports.

Task	Operating mode	Monthly	Quarterly	Half Yearly
Clean or replace filters: Disposable, or metal frame.	Replace filters with new ones if disposable. Vacuum clean or blow the dirt. Wash and dry carefully. Replace Filter if necessary by an original Lennox filter. Blocked filter will reduce the performance of the unit. THE UNIT SHOULD NEVER BE OPERATED WITHOUT FILTERS	●		
Visual check of the oil level (applicable for units equipped with sight glass) and check the oil for acidity on the refrigerant circuits	Visually check the oil level through the sight glass on the side of the compressor casing Test the oil every 3 years and after each intervention on the refrigerant circuit	●		
Clean condensate drain, indoor coils and outdoor coils (following local regulations)	It's mandatory to clean the external coils, according to the environment where the unit is located, the frequency of the cleaning varies from once in a month to minimum twice in a year. The performance and the sustainability of the machine is based on the perfect heat exchange. The use of a neutral pH cleaning product is mandatory (WARNING: Fins and copper tubes are very fragile! Any damage WILL reduce the performances of the unit).	■	■	■
Check condenser fans	Check the rotation of the fan (free rotation, detection of vibrations or bearing noises) Check for the Amps consumed on all three phases; compare it with the nominal value given in the electrical wiring diagram. Check the status of the fan blades and its protections.		■	
Check for the Amps consumed	Check for the Amps consumed on all three phases; compare with the nominal value given in the electrical wiring diagram.		■	
Check Smoke detector	Start the unit. Trigger the smoke detector with an aerosol tester. Reset unit and control.		■	
Check CLIMATIC™ control, set-points and variables	Refer to the commissioning sheet; Check all set points are set according to this document.		■	
Clean or replace electrical cabinet filters	Vacuum clean or blow the dirt. Wash and dry carefully. Replace Filter if necessary by an original filter. Risks of electrical components overheating with of dirty filters.		■	
Check refrigeration system for proper functioning	Retrieve/Check the values of Overheating and subcooling		■	
Check clock settings	Check the time and date of the control		●	
Check the position and tightness of refrigeration components	Check systematically all connections and fixings on the refrigeration circuit. Check for oil traces, eventually a leak test should be conducted. Check operating pressures correspond to the ones, indicated on the commissioning sheet		■	
Check three way valve on water coil (If applicable)	Increase room set-point 10°C above the actual room temperature. Check operation of the piston. It must move away from the valve head. Reset the control.		■	
Check the position of the crankcase heaters (around the compressor) and the proper functioning of it	Check the well fixation of the crankcase heaters, if it is tight enough And check the crankcase heaters overall working.		●	
Check defrost cycle with 4-way valve inversion.	Switch the unit to heat pump mode. Change the set point to obtain the standard defrost mode and reduce the cycle time to the min value. Check the operation of the defrost cycle.		■	

Task	Operating mode	Monthly	Quarterly	Half Yearly
Check overall working of the flow controller (only for rooftops with water condensation function)	Cut-off the compressors, stop the water circulation, then start the unit, wait for the water flow failing signal in the controller.		■	
Check the water flow (only for rooftops with water condensation function)	Measure the water flow and compare it to the initial value set in the command selection		■	
Check the plug fans (freewheel)	Check the rotation of the fan (free rotation, detection of vibration or bearing noises) Check for the Amps consumed on all three phases; compare with the nominal value given in the electrical wiring diagram.			●
Check the axial extractor fan (if the unit is equipped with)	Check the rotation of the fan (free rotation, detection of vibration or bearing noises) Check for the Amps consumed on all three phases; compare with the nominal value given in the electrical wiring diagram.			■
Check the well working of the energy recovering wheels	Check the rotation of the wheel; Check the strap tension; Replace the components in case of malfunctioning			■
Check Airflow rate safety switch (if equipped).	Shut down supply fan. The fault must be detected within 5 seconds.			●
Check freeze protection on water coil (if applicable)	Test antifreeze function (leakage rate, frost protection thermostat)			■
Check economizer actuator operation	Check all fixings and transmission. Stop the unit using the control. The fresh air damper must close. Start the unit, the fresh air damper should open. Make a forced opening and closure of the motorized dampers.			■
Check tightness of all electrical connections	Power down the unit and check and tighten all screws, terminal and electric connections (including the terminal boxes) When turning on the unit, check the deterioration of the electrical components with a thermal camera, with the unit working at 100% of its power.			■
Check HP / LP safety switches	Install a pressure gauge HP / LP and check if the safety switches overall working.			■
Check the value of the analog sensors	Install the pressure gauge calibrated to check the analog sensors. Install a thermometer calibrated to control the sensors.			■
Check the position of all sensors	Check the good positioning and the fixation of all sensors.			●
Check and clean if necessary all fresh air grids	Check the fresh air grids (if fitted). If dirty or damaged, remove them from unit and clean with high pressure water cleaner. Refit on unit once clean and dry.			●
Check electric heater element for excessive corrosion (if applicable)	Turn off the unit; Pull the electric heater out of the heater module box and check the resistances of traces of corrosion; Replace resistance as required;			■
Check anti-vibration mountings, for wear and tear.	Visually check anti-vibration mountings on compressors and centrifugal fan. Replace if damaged.			●
Check Glycol concentration in the HWC circuit and/or in the water condenser circuits	Check the glycol concentration in the pressurized water circuit. (a concentration of 30% gives a protection down to approx.. - 15°C) check the circuit pressure			■
Gas burner module check for corrosion	Pull out the burner to access the tubes (refer to Gas burner section in the IOM)			■

Task	Operating mode	Monthly	Quarterly	Half Yearly
Sweeping and cleaning the gas burner	Clean the in-shot burners and the blower wheel lightly with a brush. Sweep the flue and flue box. Wipe-off the dust from the housing of the motor. Clean combustion air inlet louvers Pull-out baffles from the tubes, sweep the tubes CHECK FLUE BOX GASKET			■
Gas supply pressures / connections checks	Refer to Gas burner section in the IOM for details			■
Check the gas regulation valve settings	Refer to Gas burner section in the IOM for details			■
Check gas burner safety switches	Refer to Gas burner section in the IOM for details			■
Check the ignition electrode and the ionization probes	Refer to Gas burner section in the IOM for details			■
Check gas fume combustion levels	Do a combustion analysis. Refer to local regulation if it exists			■
Check casing and equipment corrosion	To treat and neutralize eventual rust spots			●
Check the water tightness of the unit and it's accessories	Verify the gaskets, if cracked or ripped, repair them or replace them.			●
Check the doors gasket	Verify the gaskets; if cracked, ripped or discontinuous in these cases replace them.			●
Check and clean the water filter (only for Rooftops with water condenser)	ATTENTION: The water circuit can be under pressure. Follow the usual precautions when depressurizing the circuit before opening. Ignoring these rules can lead to accidents and cause injury to the personal.			■
Check the water tightness of the water circuit (only for Rooftops with water condenser)	Check for water leaks and repair if it's needed.			●

Technician	
Date	
Customer	
Site	
Type of access	
Serial number	
Customer reference	

Preliminary checking points	Yes	No
Safe access to the roof		
Safety walkway around the unit		
Dangerous working conditions		
Clear access according to prescription		
Final customer on site		
External damages		

Roofcurb data	Yes	No
Adjustable roofcurb		
Correct waterproffness of the roof edge		
Flashing band installed		
Water drops presence		
Isolation		

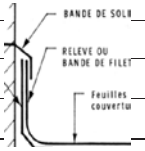

Return duct	Yes	No
Return duct		
Changes in the duct that may create additional drops of pressure or turbulences		

Supply duct	Yes	No
Air distribution grids		
Duct material		

Roofcurb	Yes	No
Level and height adjustment		
Siphons installed		
Fresh air hood installed		
Type of roofcurb		

Electrical connections	Yes	No
Wiring of main switch		
Wiring of ambient/duct sensor		
Wiring of DC		
Correct wiring for remote terminal		
BMS connection		
Rooftop adress		

Electrical data				
	Circuit 1	Circuit 2	Circuit 3	Circuit 4
Compressor current (A)				
Outdoor fan current (A)				
Electrical heater current (A)				
Electrical pre-heater current (A)				
Operational data				
Working mode	Cooling		Heating	
Supply temperature				
Return temperature				
Outdoor temperature/humidity				
Supply fan				
Mode	%	Nominal current measured (A)		
Nominal current (A)		Fresh airflow (m ³ /h)		
Extraction fan				
Mode	%	Nominal current measured (A)		
Nominal current (A)		Fresh airflow (m ³ /h)		
Refrigerant circuit data				
Operating mode	Cooling		Heating	
	Circuit1	Circuit 2	Circuit 1	Circuit 2
Suction temperature				
Evaporating temperature				
Condensing temperature				
Liquid line temperature				
Backflow/ Return temperature				
Refrigerant (Type/charge)				
Superheating				
Subcooling				
Low pressure safety				
High pressure safety				
Water coil				
Inlet water temperature		Outlet water temperature		
Operating checking			yes	No
3 ways valve				
Air dampers				
Dehumidify system				
Smoke detector				
Remote control				
Climatic setting				
Fresh air percentage				
Cooling set point				
Heating set point				
Airflow setting				
No filter setting				
Dirty filter setting				
Airflow pressostat setting				

General information

Site name:	Serial Number:	
Site address:		
Site operator:		
Cooling load :		
Refrigerant type:	Refrigerant quantity (kg)	
Unit manufacturer	Year of installation	

Refrigerant additions

Date	Engineer	Quantity (kg)	Reason for addition

Refrigerant removal

Date	Engineer	Quantity (kg)	Reason for removal

Leak tests (part 1)

Date	Engineer	Test Result	Follow up action required

Leak tests (part 2)

Date	Engineer	Test Result	Follow up Action Required

Follow up actions

Date	Engineer	Related to test dated	Action taken

Testing of automatic leak detection system (if fitted)

Date	Engineer	Test result	Comments

SALES OFFICES :

BELGIUM AND LUXEMBOURG

+32 3 633 3045

FRANCE

+33 1 64 76 23 23

GERMANY

+49 (0) 211 950 79 60

ITALY

+39 02 495 26 200

NETHERLANDS

+31 332 471 800

POLAND

+48 22 58 48 610

PORTUGAL

+351 229 066 050

SPAIN

+34 915 401 810

UKRAINE

+38 044 585 59 10

UNITED KINGDOM AND IRELAND

+44 1604 669 100

OTHER COUNTRIES :

LENNOX DISTRIBUTION

+33 4 72 23 20 20

Due to LENNOX EMEA ongoing commitment to quality, the specifications, ratings and dimensions are subject to change without notice and without incurring liability. Improper installation, adjustment, alteration, service or maintenance can cause property damage or personal injury. Installation and service must be performed by a qualified installer and servicing agency.

